

Federal Democratic Republic of Ethiopia
Ministry of Transport
Aircraft Accident Investigation Bureau

Aircraft Accident Investigation Preliminary Report
Ethiopian Airlines Group
B737-8 (MAX) Registered ET-AVJ
28 NM South East of Addis Ababa, Bole International Airport
March 10, 2019

Report No. AI-01/19

FOREWORD

The Aircraft Accident Investigation Bureau of Ethiopia

The Aircraft Accident Investigation Bureau (AIB) is the investigation authority in Ethiopia responsible to the Ministry of Transport for the investigation of civil aircraft accidents and serious incidents in Ethiopia.

The mission of the AIB is to promote aviation safety through the conduct of independent, separate investigations without prejudice to any judicial or administrative action consistent with Annex 13 to the Convention on International Civil Aviation.

The AIB conducts the investigations in accordance with the proclamation No 957/16 and Annex 13 to the Convention on International Civil Aviation, which governs how member States of the International Civil Aviation Organization (ICAO) conduct aircraft accident investigations internationally.

The investigation process involves the gathering, recording and analysis of all available information on the accidents and incidents; determination of the causes and/or contributing factors; identification of safety issues; issuance of safety recommendations to address these safety issues; and completion of the investigation report. In carrying out the investigations, the AIB will adhere to ICAO's stated objective, which is as follows:

“The sole objective of the investigation of an accident or incident shall be the prevention of accidents and incidents; it is not the purpose of this activity to apportion blame or liability”.

ACRONYMS

AIB	Accident Investigation Bureau
AFM	Aircraft Flight Manual
AGB	Accessory Gear Box
AGL	Above Ground Level
AND	Aircraft Nose Down
ANU	Aircraft Nose Up
AOA	Angle of Attack
AP	Autopilot
APU	Auxiliary Power Unit
ATC	Air Traffic Control
BEA	Bureau d'Enquête Analyse pour la sécurité de l'aviation civile
CG	Centre of Gravity
CGO	Cargo
CSMU	Crash survivable Memory Unit
CVR	Cockpit Voice Recorder
DFDR	Digital Flight Data Recorder
EASA	European Union Aviation Safety Agency
ECAA	Ethiopian Civil Aviation Authority
FAA	Federal Aviation Administration
FCOM	Flight Crew Operation Manual
FDRE	Federal Democratic Republic of Ethiopia
GPS	Global Positioning System
GPWS	Ground Proximity Warning System
GVI	General Visual Inspection

HPC	High Pressure Compressor
HPT	High Pressure Turbine
IC	Investigation Committee
ICAO	International Civil Aviation Authority
IFSO	In-flight Security Officer
IIC	Investigator In-charge
LMC	Last Minute Change
LNAV	Lateral Navigation
LPC	Low Pressure Compressor
LPT	Low Pressure Turbine
MLB	Maintenance Log Book
NM	Nautical Miles
NOTAM	Notice to Air Men
NTSB	National Transportation Safety Board
PAX	Passenger
PFD	Primary Flight Display
SAR	Search and Rescue
TCDS	Type Certificate data Sheet
TGB	Transfer Gear Box
UTC	Universal Time Coordinated
Vmo	Max operating velocity
VNAV	Vertical Navigation

Synopsis

The Accident was notified by the operator/ATC to the Accident Investigation Bureau the same day right after the accident occurred.

Aircraft	Boeing 737-8MAX registered ET-AVJ
Date and time	10 March 2019 at 05:44 UTC
Operator	Ethiopian Airlines Group
Place of the Accident	28 NM South East of Addis Ababa Bole International Airport
Type of flight	Scheduled passengers flight ET-302 Addis Ababa (Ethiopia) – Jomo Kenyatta (Kenya)
Persons on board	Captain; First-Officer; 5 Cabin Crew; 1 In Flight Security Officer (IFSO); 149 passengers from different countries
Consequences and damage	157 fatalities; aircraft destroyed

Executive summary

On March 10, 2019, at 05:38 UTC, Ethiopian Airlines flight 302, Boeing 737-8(MAX), ET-AVJ, took off from Addis Ababa Bole Int. Airport bound to Nairobi, Kenya Jomo Kenyatta Int. Airport. Shortly after takeoff, the Angle of Attack sensor recorded value became erroneous and the left stick shaker activated and remained active until near the end of the flight. In addition, the airspeed and altitude values from the left air data system began deviating from the corresponding right side values. Due to flight control problems, the Captain was unable to maintain the flight path and requested to return back to the departure airport. The crew lost control of the aircraft which crashed at 5: 44 UTC 28 NM South East of Addis Ababa near Ejere village.

Table of Contents

Foreword.....	2
Acronyms	3
Table of Contents	6
Organisation of the investigation	8
1 Factual information	9
1.1 History of Flight.....	9
1.2 Injuries to persons	12
1.3 Damage to Aircraft.....	12
1.4 Other damage	12
1.5 Personnel Information.....	13
1.5.1 Pilot in Command.....	13
1.5.2 First-officer	13
1.6 Aircraft Information.....	14
1.6.1 General.....	14
1.6.2 AIRCRAFT FLIGHT CONTROL SYSTEM DESCRIPTION	15
1.6.3 Engines	18
1.6.4 Aircraft Flight and Maintenance Log.....	19
1.6.5 Weight and balance	20
1.7 Meteorological Information	21
1.8 Aids to Navigation.....	21
1.9 Communications	21
1.10 Aerodrome Information.....	21
1.11 Flight Recorders.....	22
1.11.1 Digital Flight Data Recorder	22
1.11.2 Cockpit Voice Recorder	23
1.12 Wreckage and Impact Information	23
1.13 Medical and pathological Information	24
1.14 Fire.....	24
1.15 Survival Aspects	24
1.16 Organizational and Management Information.....	24
1.16.1 Aircraft Operator Information.....	24
1.16.2 Operation manual extracts.....	24
2 Initial Findings	25

3 Safety actions taken.....25

4 Safety recommendationS.....25

5 APPENDICES26

Appendix 126

Appendix 228

Appendix 330

Appendix 432

ORGANISATION OF THE INVESTIGATION

On Sunday 10th March 2019 at around 05:47, FDRE Ministry of Transport and AIB were informed the loss of radio and radar contact with flight ET 302 a few minutes after take-off from Addis Ababa Bole International Airport.

After having established without doubt that the Aircraft had disappeared, the Ethiopian Authorities launched a technical investigation. In accordance with article 26 of the Convention and ICAO Annex 13 "Aircraft Accident and Incident Investigation", an Investigation Committee (IC) from Ethiopian AIB investigators was formed by a ministerial decree issued by the Minister of Transport in order to conduct the technical investigation. An investigator-in-charge (IIC) was designated in the same decree to lead and initiate the investigation immediately. As per Annex 13 provisions, in the investigation participated:

ECAA and Ethiopian Airlines Group - Technical Advisor to AIB

NTSB - Accredited Representative State of Design and Manufacturer

BEA - Accredited representative, State which provided facilities & experts for the read out of DFDR & CVR

EASA -Technical Advisor to AIB

As per the Ethiopian Government decision and agreement between the FDRE Ministry of Transport and the French Bureau d'Enquête Analyse pour la sécurité de l'aviation civile (BEA), the DFDR and CVR were read at the BEA facilities at Le Bourget, near Paris, France. Both recorders were transported directly to the BEA under the custody of the State of Occurrence accompanied by members from the IC and readings were performed by BEA personnel in association with and under the direct supervision of the IC. On request of Ethiopia and as per annex 13 article 5.23, BEA has appointed an accredited representative.

Working groups were formed as follows:

- Operations
- Maintenance & Airworthiness group
- Power plant group
- Autopsy examination group
- DFDR and CVR group

A Search & Rescue (SAR) team performed search by Ethiopian Air force, Ethiopian Air lines Group and Abyssinian flight service. Search operations were conducted in full coordination with Federal, Regional police and other Government bodies.

It was also decided that media relations till the release of the final investigation report were to be handled by the FDRE Ministry of Transport Minister with factual data and information relayed through the IIC directly to the Minister.

1 FACTUAL INFORMATION

1.1 HISTORY OF FLIGHT

On March 10, 2019, at about 05:44 UTC¹, Ethiopian Airlines flight 302, a Boeing 737-8 (MAX), Ethiopian registration ET-AVJ, crashed near Ejere, Ethiopia, shortly after takeoff from Addis Ababa Bole International Airport (HAAB), Ethiopia. The flight was a regularly scheduled international passenger flight from Addis Ababa to Jomo Kenyatta International Airport (HKJK), Nairobi, Kenya. There were 157 passengers and crew on board. All were fatally injured, and the Aircraft was destroyed.

The following is based on the preliminary analysis of the DFDR, CVR and ATC communications. As the investigation continues, revisions and changes may occur before the final report is published.

At 05:37:34, ATC issued take off clearance to ET-302 and to contact radar on 119.7 MHz.

Takeoff roll began from runway 07R at a field elevation of 2333.5 m at approximately 05:38, with a flap setting of 5 degrees and a stabilizer setting of 5.6 units. The takeoff roll appeared normal, including normal values of left and right angle-of-attack (AOA). During takeoff roll, the engines stabilized at about 94% N1, which matched the N1 Reference recorded on the DFDR. From this point for most of the flight, the N1 Reference remained about 94% and the throttles did not move. The N1 target indicated non data pattern 220 seconds before the end of recording. According to the CVR data and the control column forces recorded in DFDR, captain was the pilot flying.

At 05:38:44, shortly after liftoff, the left and right recorded AOA values deviated. Left AOA decreased to 11.1° then increased to 35.7° while value of right AOA indicated 14.94°. Then after, the left AOA value reached 74.5° in ¾ seconds while the right AOA reached a maximum value of 15.3°. At this time, the left stick shaker activated and remained active until near the end of the recording. Also, the airspeed, altitude and flight director pitch bar values from the left side noted deviating from the corresponding right side values. The left side values were lower than the right side values until near the end of the recording.

At 05:38:43 and about 50 ft radio altitude, the flight director roll mode changed to LNAV.

At 05:38:46 and about 200 ft radio altitude, the Master Caution parameter changed state. The First Officer called out Master Caution Anti-Ice on CVR. Four seconds later, the recorded Left AOA Heat parameter changed state.

At 05:38:58 and about 400 ft radio altitude, the flight director pitch mode changed to VNAV SPEED and Captain called out "Command" (standard call out for autopilot engagement) and an autopilot warning is recorded.

At 05:39:00, Captain called out "Command".

At 05:39:01 and about 630 ft radio altitude, a second autopilot warning is recorded.

¹ All times listed is Universal Coordinated Time (UTC), as recorded on the FDR.

At 05:39:06, the Captain advised the First-Officer to contact radar and First Officer reported SHALA 2A departure crossing 8400 ft and climbing FL 320.

Between liftoff and 1000 ft above ground level (AGL), the pitch trim position moved between 4.9 and 5.9 units in response to manual electric trim inputs. At 1000 ft AGL, the pitch trim position was at 5.6 units.

At 05:39:22 and about 1,000 feet the left autopilot (AP) was engaged (it disengaged about 33 seconds later), the flaps were retracted and the pitch trim position decreased to 4.6 units.

Six seconds after the autopilot engagement, there were small amplitude roll oscillations accompanied by lateral acceleration, rudder oscillations and slight heading changes. These oscillations continued also after the autopilot was disengaged.

At 05:39:29, radar controller identified ET-302 and instructed to climb FL 340 and when able right turns direct to RUDOL and the First-Officer acknowledged.

At 05:39:42, Level Change mode was engaged. The selected altitude was 32000 ft. Shortly after the mode change, the selected airspeed was set to 238 kt.

At 05:39:45, Captain requested flaps up and First-Officer acknowledged. One second later, flap handle moved from 5 to 0 degrees and flaps retraction began.

At 05:39:50, the selected heading started to change from 072 to 197 degrees and at the same time the Captain asked the First-Officer to request to maintain runway heading.

At 05:39:55, Autopilot disengaged,

At 05:39:57, the Captain advised again the First-Officer to request to maintain runway heading and that they are **having flight control problems**.

At 05:40:00 shortly after the autopilot disengaged, the FDR recorded an automatic aircraft nose down (**AND**) activated for 9.0 seconds and pitch trim moved from 4.60 to 2.1 units. The climb was arrested and the aircraft descended slightly.

At 05:40:03 Ground Proximity Warning System (GPWS) "DON'T SINK" alerts occurred.

At 05:40:05, the First-Officer reported to ATC that they were unable to maintain SHALA 1A and requested runway heading which was approved by ATC.

At 05:40:06, left and right flap position reached a recorded value of 0.019 degrees which remained until the end of the recording.

The column moved aft and a positive climb was re-established during the automatic AND motion.

At 05:40:12, approximately three seconds after AND stabilizer motion ends, electric trim (from pilot activated switches on the yoke) in the Aircraft nose up (ANU) direction is recorded on the DFDR and the stabilizer moved in the ANU direction to 2.4 units. The Aircraft pitch attitude remained about the same as the back pressure on the column increased.

At 05:40:20, approximately five seconds after the end of the ANU stabilizer motion, a **second instance of automatic AND** stabilizer trim occurred and the stabilizer moved down and reached 0.4 units.

From 05:40:23 to 05:40:31, three Ground Proximity Warning System (GPWS) "DON'T SINK" alerts occurred.

At 05:40:27, the Captain advised the First-Officer to trim up with him.

At 05:40:28 Manual electric trim in the ANU direction was recorded and the stabilizer reversed moving in the ANU direction and then the trim reached 2.3 units.

At 05:40:35, the First-Officer called out "stab trim cut-out" two times. Captain agreed and First-Officer **confirmed stab trim cut-out**.

At 05:40:41, approximately five seconds after the end of the ANU stabilizer motion, a **third instance of AND** automatic trim command occurred without any corresponding motion of the stabilizer, which is consistent with the stabilizer trim cutout switches were in the "cutout" position

At 05:40:44, the Captain called out three times "Pull-up" and the First-Officer acknowledged.

At 05:40:50, the Captain instructed the First Officer to advise ATC that they would like to maintain 14,000 ft and **they have flight control problem**.

At 05:40:56, the First-Officer requested ATC to maintain 14,000 ft and reported that they are having flight control problem. ATC approved.

From 05:40:42 to 05:43:11 (about two and a half minutes), the stabilizer position gradually moved in **the AND direction from** 2.3 units to 2.1 units. During this time, aft force was applied to the control columns which remained aft of neutral position. The left indicated airspeed increased from approximately 305 kt to approximately 340 kt (VMO). The right indicated airspeed was approximately 20-25 kt higher than the left.

The data indicates that aft force was applied to both columns simultaneously several times throughout the remainder of the recording.

At 05:41:20, the right overspeed clacker was recorded on CVR. It remained active until the end of the recording.

At 05:41:21, the selected altitude was changed from 32000 ft to 14000 ft.

At 05:41:30, the Captain requested the First-Officer to pitch up with him and the First-Officer acknowledged.

At 05:41:32, the left overspeed warning activated and was active intermittently until the end of the recording.

At 05:41:46, the Captain asked the First-Officer if the trim is functional. The First-Officer has replied that the **trim was not working** and asked if he could try it manually. The Captain told him to try. At 05:41:54, the First-Officer replied that it is not working.

At 05:42:10, the Captain asked and the First-Officer requested radar control a **vector to return** and ATC approved.

At 05:42:30, ATC instructed ET-302 to turn right heading 260 degrees and the First-Officer acknowledged.

At 05:42:43, the selected heading was changed to 262 degrees.

At 05:42:51, the First-Officer mentioned Master Caution Anti-Ice. The Master Caution is recorded on DFDR.

At 05:42:54, both pilots called out "left alpha vane".

At 05:43:04, the Captain asked the First Officer to pitch up together and said that pitch is not enough.

At 05:43:11, about 32 seconds before the end of the recording, at approximately 13,400² ft, two momentary manual electric trim inputs are recorded in the ANU direction. The stabilizer moved in the ANU direction from 2.1 units to 2.3 units.

At 05:43:20, approximately five seconds after the last manual electric trim input, **an AND automatic trim command** occurred and the stabilizer moved in the AND direction from 2.3 to 1.0 unit in approximately 5 seconds. The aircraft began pitching nose down. Additional simultaneous aft column force was applied, but the nose down pitch continues, eventually reaching 40° nose down. The stabilizer position varied between 1.1 and 0.8 units for the remainder of the recording.

The left Indicated Airspeed increased, eventually reaching approximately 458 kts and the right Indicated Airspeed reached 500 kts at the end of the recording. The last recorded pressure altitude was 5,419 ft on the left and 8,399 ft on the right.

1.2 INJURIES TO PERSONS

Injuries	Flight Crew	Passengers	Total in Aircraft	Others
Fatal	8	149	157	-
Serious	-	-	-	-
Minor	-	-	-	-
None	-	-	-	-
TOTAL	8	149	157	-

1.3 DAMAGE TO AIRCRAFT

The aircraft is completely destroyed.

1.4 OTHER DAMAGE

No other damage.

² The FDR records standard pressure altitude values which are not corrected for the airport barometer setting.

1.5 PERSONNEL INFORMATION

1.5.1 PILOT IN COMMAND

According to Ethiopian Airlines records, the captain has the following flight experience:

- Total hours: 8122
- Total hours in B737: 1417
- Total hours in B737-8 MAX: 103
- Flight time in previous 90 days: 266 hours and 9 minutes
- Flight time in previous 7 days: 17 hours and 43 minutes
- Flight time in previous 72 hours: no flight time

The pilot in command was 29 years old. According to Ethiopian Civil Aviation Authority (ECAA) records, the Captain's most recent simulator training experience was September 30, 2018, and his most recent simulator proficiency check was October 1, 2018. The captain completed the Ethiopian Aviation Academy on July 23, 2010. A review of the captain's training records indicated that he received his 737-800 First Officer type rating on January 31, 2011 and completed his PIC type rating for the 737-800 October 26, 2017. 737MAX differences training on 3 July, 2018.

The pilot in command is type rated as a First Officer of the following types of aircrafts: B737-7/800, B767/757, B777 and B787. As pilot in command, he is rated on B737-7/800 and B737MAX.

The pilot's ECAA license allowed him to act as pilot-in-command in commercial air transport operations in a Boeing 737-7/800 (dated October 26, 2017) and Boeing 737 MAX (dated July 3, 2018.)

The pilot had a first-class medical certificate with no limitations dated December 12, 2018. A review of the medical exam that resulted in the issuance of this certificate showed no vision or hearing deficiencies, and on the certificate application, the pilot stated he was taking no prescription or non-prescription medications. He reported no medical conditions.

1.5.2 FIRST-OFFICER

According to Ethiopian Airlines records, the First-Officer has the following flight experience:

- Total hours: 361
- Total hours in B737: 207
- Total hours in B737-8 MAX: 56
- Flight time in previous 90 days: 207 hours and 26 minutes
- Flight time in previous 7 days: 10 hours and 57 minutes
- Flight time in previous 72 hours: 5 hours and 25 minutes

The first-officer was 25 years old. According to ECAA records, the first-officer's most recent simulator event was listed as a proficiency check and occurred on December 3, 2018. His line training/check (conducted in the B737 aircraft) was completed on January 31, 2019.

The first-officer's ECAA license allowed him to act as first-officer in commercial air transport operations in Boeing 737-7/800 (dated December 12, 2018) and Boeing 737 MAX (dated December 12, 2018.)

The first-officer had a first-class medical certificate with no limitations dated July 30, 2018. A review of the medical exam that resulted in the issuance of this certificate showed no vision or hearing deficiencies, and on the certificate application, the pilot stated he was taking no prescription or non-prescription medications. He reported no medical conditions.

1.6 AIRCRAFT INFORMATION

1.6.1 GENERAL

The 737-8 (MAX) is a low wing, narrow body single aisle, jet transport with a conventional tail unit configuration, powered by two high bypass turbofan CFM Leap-1B engines mounted on pylons beneath the wings. The Aircraft is manufactured by Boeing Commercial Aircraft and is the fourth generation of the 737 series. According to The Boeing Company's website, the Aircraft was designed to carry 162-178 passengers, depending on seating configuration. The 737-8 MAX was launched on August 30, 2017, and type certificated with the FAA on March 8, 2017.

ET-AVJ was a 737-8 MAX single aisle transport aircraft configured in a 160 passenger multi-class arrangement manufactured by the Boeing Company and delivered to Ethiopian Airlines on 15 November, 2018. The Aircraft was powered by two LEAP-1B Turbo Fan Engines manufactured by CFM International. The Aircraft had 1330.3 hours with a total of 382 cycles at the time of the accident.

Registration Number:	ET-AVJ
Aircraft Serial Number:	62450
Aircraft Manufacturer:	Boeing Commercial Aircraft
Model:	737-8 (MAX)
Engine Manufacturer:	CFM International
Engine Model:	LEAP-1B28B1G05
Manufactured Year:	2018
Aircraft Type:	Fixed Wing Multi-Engine
Engine Type:	Turbo Fan
Aircraft Category:	Transport
Number of Engines:	2
Seating arraignment:	Multi-Class
PAX Seating Capacity:	160
Max. T/O Weight:	82,190 kg
Total Time:	1330.3 hours
Total Cycles:	382
Aircraft Owner:	Ethiopian Leasing (5-737) LTD

Address: C/O WALKERS CORPORATE LIMITED, CAYMAN CORPORATE CENTER, 27 HOSPITAL ROAD, GEORGE TOWN, GRAND CAYMAN KY1-9008, CAYMAN ISLANDS

Aircraft Operator: Ethiopian Airlines Group

Address: Bole International Airport P.O. Box 1755 Addis Ababa, Ethiopia

Operator Certificate Number: CATO-01/270295

1.6.2 AIRCRAFT FLIGHT CONTROL SYSTEM DESCRIPTION

Introduction

The primary flight control system uses conventional control wheel, column and pedals linked mechanically to hydraulic power control units which command the primary flight control surfaces; ailerons, elevators and rudder. The flight controls are powered by redundant hydraulic sources; system A and system B.

Flight Control Surfaces Location

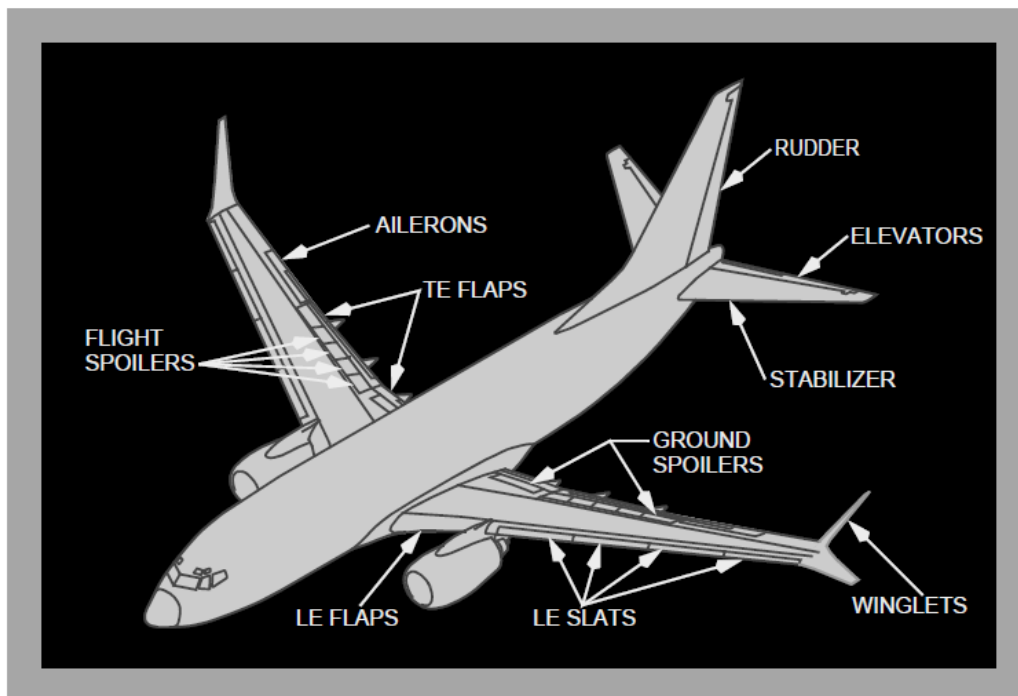

Pilot Controls

The pilot controls consist of: The columns and wheels are connected through transfer mechanisms which allow the pilots to bypass a jammed control. There is a rigid connection between both pairs of rudder pedals. The SPEED BRAKE lever allows manual or automatic symmetric actuation of the spoilers.

- Two control columns; two control wheels; two pairs of rudder pedals
- SPEED BRAKE lever; FLAP lever

- STAB TRIM cutout switches; STAB TRIM override switch
- Stabilizer trim switches; stabilizer trim wheel
- AILERON trim switches; RUDDER trim control; YAW DAMPER switch
- ALTERNATE FLAPS master switch; alternate flaps position switch
- FLT CONTROL switches; flight SPOILER switches

Roll Control

The roll control surfaces consist of hydraulically powered ailerons and flight spoilers, which are controlled by rotating either control wheel.

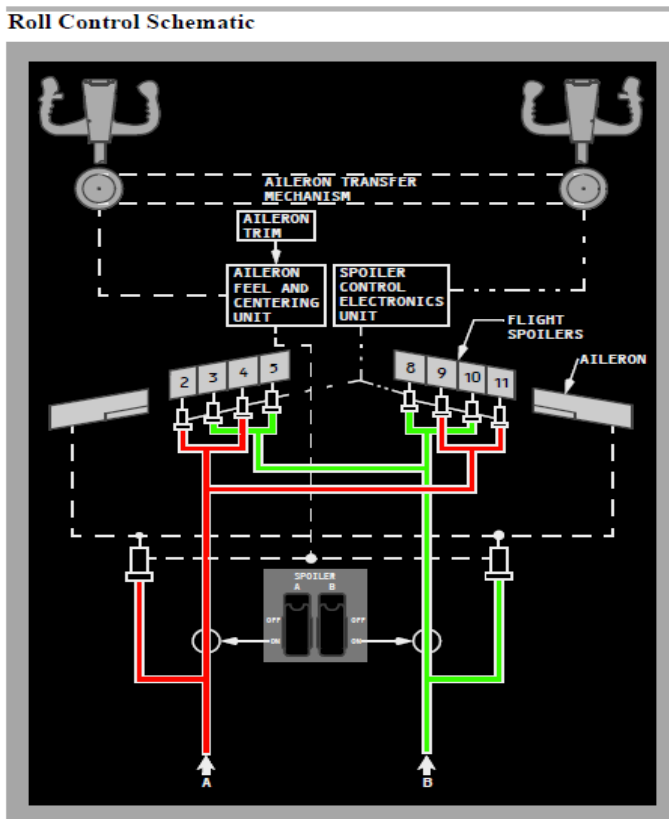

Pitch Control

The pitch control surfaces consist of hydraulically powered elevators and an electrically powered stabilizer. The elevators are controlled by forward or aft movement of the control column. The stabilizer is controlled by autopilot trim or manual trim.

Mach Trim System

A Mach trim system provides speed stability at the higher Mach numbers. Mach trim is automatically accomplished above Mach .615 by adjusting the elevators with respect to the stabilizer as speed increases.

Stabilizer

The horizontal stabilizer is positioned by a single electric trim motor controlled through either the stab trim switches on the control wheel or autopilot trim. The stabilizer may also be positioned by manually rotating the stabilizer trim wheel.

Stabilizer Trim

Stabilizer trim switches on each control wheel actuate the electric trim motor through the main electric stabilizer trim circuit when the aircraft is flown manually. With the autopilot engaged, stabilizer trim is accomplished through the autopilot stabilizer trim circuit. The main electric and autopilot stabilizer trim have two speed modes: high speed with flaps extended and low speed with flaps retracted. If the autopilot is engaged, actuating either pair of stabilizer trim switches automatically disengages the autopilot. The stabilizer trim wheels rotate whenever electric stabilizer trim is actuated.

The STAB TRIM PRI cutout switch and the STAB TRIM B/U cutout switch are located on the control stand. If either switch is positioned to CUTOUT, both the autopilot and main electric trim inputs are disconnected from the stabilizer trim motor.

Control column actuated stabilizer trim cutout switches stop operation of the main electric and autopilot trim when the control column movement opposes trim direction. When the STAB TRIM override switch is positioned to OVRD, electric trim can be used regardless of control column position.

1.6.3 ENGINES

The accident engines were CFM LEAP-1B28B1, a high bypass, dual rotor, axial flow turbofans. The engine consists of 3 major assemblies: low pressure compressor (LPC), core engine, and low-pressure turbine (LPT). The core engine consists of a two-stage high pressure turbine (HPT) which drives the ten-stage high pressure compressor (HPC). The four-stage integrated fan and low-pressure compressor (booster) is driven by a five-stage LPT. The annular designed combustion chamber increases the HPC discharge air velocity to drive the high- and low-pressure turbines. An accessory drive system provides drive requirements for engine mounted aircraft accessories and is driven by the high-pressure module. The accessory drive system includes two sub-modules which can be removed or installed at engine level, the accessory gearbox (AGB) and the transfer gearbox (TGB).

According to the engine's FAA Type Certificate Data Sheet (TCDS) E00088EN, Revision 4, dated November 30, 2018, the engine has a maximum takeoff thrust rating of 29,317 pounds flat-rated to 86°F (30°C) and a maximum continuous thrust rating of 28,690 pounds flat-rated to 77°F (25°C).

Both engines were found buried in the ground at a depth of approximately 10 meters. To access the buried wreckage (engines, aircraft structure and components), backhoes were used to remove the wreckage from the area around the impact point.

The field investigation did not find evidence of any non-containment event (engine components ejected out of the side of the engine), or any other anomalies with either engine that would have precluded their normal operation. Evidence of the field investigation indicated that the LP and HP spools of both engines were rotating, evidence of high-speed axial compression of the both engines, and the engine was operating at power at the time of impact. A summary of engine usage is listed below:

Manufacturer: CFM International

Type/Model: LEAP-1B28B1

Serial Number-1 engine: 602722

Time Since New: 1330 hours

Cycles Since Install: 382 cycles

Cycles Since New: 382 cycles

Serial Number-2 engine: 602695

Time Since New: 1330 hours

Cycles Since Install: 382 cycles

Cycles Since New: 382 cycles

1.6.4 AIRCRAFT FLIGHT AND MAINTENANCE LOG

The Maintenance Log Book (MLB) was reviewed in detail for the last 39 flights from 26 February 2019 until 09 March 2019 (previous flight to the accident flight). In addition, the records were reviewed for the 1A check conducted in early February.

Over the previous 39 flights, the MLB cited in particular: Captain's flight compartment PC power outlet has no power; the crew oxygen cylinder was replaced due to low pressure; and the APU would not start. All three issues led to maintenance actions and did not reoccur.

In addition, the MLB was reviewed at a higher level for all flights back to the delivery flight in November 2018. Maintenance actions of relevance occurred in early December 2018 and involved several write-ups involving temporary erratic airspeed and altitude fluctuations as well as a report of the aircraft rolling during autopilot operation and altitude and vertical speed indication on the PFD showed an erratic and exaggerated indication. Maintenance actions were performed and none were reported to have reoccurred.

Log Ref	Date	DEP	ARR	Write ups	Rectify Action
24640	10-Dec-18	LAD	ADD	Capt. Side altimeter indication erratically showed a descent and a lower level and back to normal indication at FL380	BITE on OMF shows no related fault. GVI performed for static ports, no damage found; no FOD found. BITE done on FMC for ADIRU faults, found none. OPC performed as per AMM 34-21-00-710-806; test passed
24628	7-Dec-18	LAO	ADD	During approach @ 1000' AGL the A/C starts rolling to the right with the autopilot engaged.	BITE done of FMC CDU (DFCS); no fault found as per 22-11-34-040-80. Performed land verify test as per AMM 22-11-00-700-801; found normal
23645	4-Dec-18	DOH	ADD	During approach at 8600 feet, altimeter rapidly descended and returned to normal causing autopilot to revert to CWS "P", L-NAV remained engaged.	IFIM 34-31-00-810-819 - No existing fault found on OMF. Fault history found on OMF is that MMR is not giving valued input. From OMF, as per the manual MMR operational test. Performed test - passed. Per AMM 34-37-00-710-801, ran op test; passed
23639	3-Dec-18	DAR	ADD	After take-off, altitude and vertical speed indicator on both PFD's showed an erratic and exaggerated indications (moving up and down very rapidly) for about 2 sec. and then returned back to normal	AMM 46-13-02-710-801 OMF shows no fault in inbound FDE. Fault has no fault history and also has no related fault. FMC operational test performed as per AMM 34-61-00-710-801 and test shows no fault

The only scheduled check of the Aircraft occurred from 01 February and 04 February 2019. This is a routine check and General Visual Inspection (GVI) of various areas of the airframe. No major discrepancies or repairs were noted for this check.

1.6.5 WEIGHT AND BALANCE

The Aircraft left the stand with a weight of 72,011 kg.

The weight was distributed as follows:

- Operating Empty Weight: 47,090 kg;
- Passenger weight (148 adults and 2 children): 11,309 kg;
- A last-minute change (LMC) corrected the final weight to take into account the no-show of one passenger (- 100 kg).
- Hold weight (baggage³): 2,912 kg;
- Block fuel: 10,700 kg.

The taxiing fuel weight was 115 kg. The takeoff weight was 71,896 kg. The regulated takeoff weight is 72,400 kg.

³ There was 205 kg of mail on board the aircraft according to the load sheet
20 of 33

Takeoff Center of Gravity (CG) was 23.12.

For this flight, the weight and balance determined by the crew of the Aircraft were within the limits defined by the manufacturer.

1.7 METEOROLOGICAL INFORMATION

The accident occurred at 0544 UTC. The pertinent Addis Ababa Bole International Airport, (HAAB) surface weather observations provided by the National Meteorological Agency of Ethiopia are as follows:

MET REPORT HAAB 100500Z

Wind - runway 25: 060 degrees 8 kt, and runway 07: 050 degrees 8 kt
Visibility: 10km; few cloud 750 m; temperature: 16°C; dew point: 10°C
QNH: 1029 hPa; QFE: 776.8 hPa

MET REPORT HAAB 100530Z

Wind - runway 25: 070 degrees 10kt, runway 07: 050 degrees, 10kt
Visibility: 10km; few cloud 750 m; temperature: 17°C; dew point: 09°C
QNH: 1029 hPa; QFE: 777 hPa

1.8 AIDS TO NAVIGATION

Not applicable

1.9 COMMUNICATIONS

The Ethiopian Accident Investigation Bureau obtained VHF communications information and transcribed pertinent portions of the communications between the flight crew and air traffic control. The VHF Communication frequencies involved were: Ground - 121.29 MHz, Tower - 118.1 MHz & Departure (radar) is 119.7 MHz.

1.10 AERODROME INFORMATION

Addis Ababa aerodrome has two runways which consisted of two parallel paved surfaces designated 07R/25L and 07L/25R. The elevation of the airport is 2333.5 m. The Aircraft took off on runway 07R which was 3800 m long and 45 m wide. The runway was not grooved but visual inspection revealed a very smooth runway with proper crowning

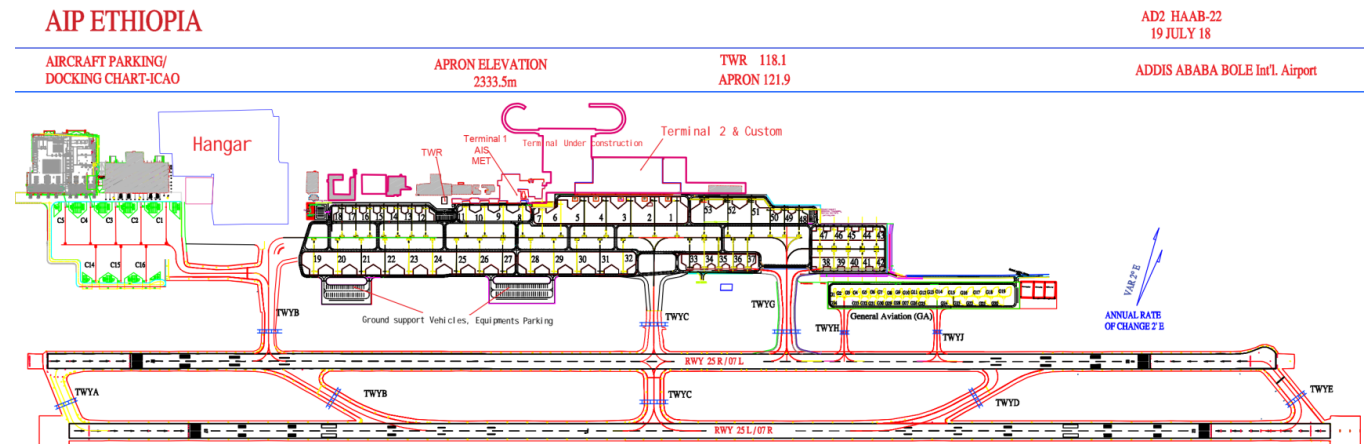

1.11 FLIGHT RECORDERS

The Aircraft was equipped with a Digital Flight Data Recorder (DFDR) and Cockpit Voice Recorder (CVR), which were located in the aft cabin and aft cargo hold (respectively) section of the aircraft.

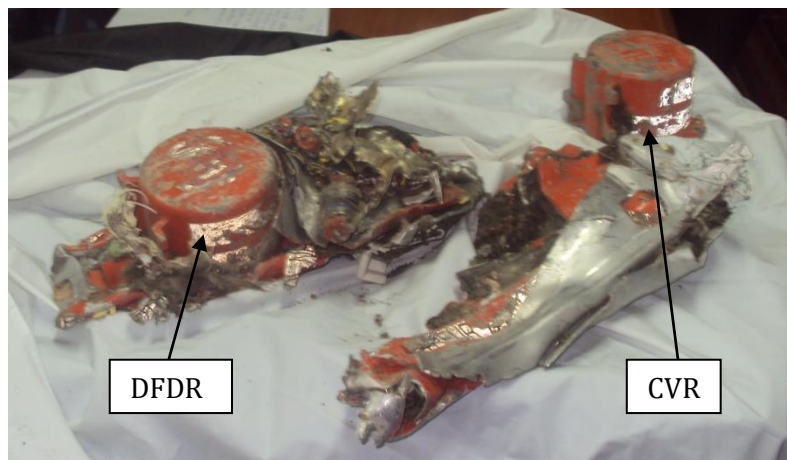

DFDR and CVR as discovered on the accident site.

1.11.1 DIGITAL FLIGHT DATA RECORDER

The aircraft was fitted with a FA2100 NAND DFDR manufactured by L3-com with part number 2100-4945-22 and serial number 001217995.

On 11 March 2019, the DFDR was recovered from the accident site by the AIB. The DFDR chassis with the Crash Survivable Memory Unit (CSMU) attached were transported to the French BEA recorder facility for data downloading. The recorder read-out was performed by BEA (Bureau d'Enquête Analyse pour la sécurité de l'aviation civile) investigators for the Ethiopian Accident Investigation Bureau (AIB) under the authority of Ethiopian investigators with the participation of the U.S National Transportation Safety Board (NTSB), The Boeing Company, U.S Federal Aviation Administration (FAA) and EASA.

The memory unit recorded 1790 parameters and approximately 73 hours of aircraft operation, and contained 16 flights, including the accident flight.

Preliminary DFDR data are shown on the figure in Appendix 1

1.11.2 COCKPIT VOICE RECORDER

The aircraft was fitted with a FA2100 NAND CVR manufactured by L3 Communications with part number 2100-1925-22 and serial number 001289168.

On 11 March 2019, the CVR was recovered from the accident site by the AIB. The CVR CSMU was transported to the BEA recorder facility for data downloading. The CSMU was found separated from the chassis during wreckage recovery. The read-out was performed by BEA investigators under the authority of the Ethiopian Accident Investigation Bureau (AIB), with the participation the National Transportation Safety Board (NTSB) of United States of America, the Boeing Company, and the Federal Aviation Administration (FAA).

The memory unit recorded 2 hours, 4 minutes and 14 seconds of aircraft operation, which contained 2 flights including the accident flight.

1.12 WRECKAGE AND IMPACT INFORMATION

The accident site was located near Ejere, Ethiopia with a GPS location of approximately 8.8770 N, 39.2516 E.

The Aircraft impacted in a farm field and created a crater approximately 10 meters deep (last aircraft part found) with a hole of about 28 meters width and 40 meters length. Most of the wreckage was found buried in the ground; small fragments of the aircraft were found scattered around the site in an area by about 200 meters width and 300 meters long.

The damages to the aircraft are consistent with a high energy impact.



Top view of the crater



Close view of the crater before excavation

1.13 MEDICAL AND PATHOLOGICAL INFORMATION

Medical and pathological information is under study and will be accessible in the final investigation.

1.14 FIRE

There was no evidence of fire.

1.15 SURVIVAL ASPECTS

This accident was not survivable.

1.16 ORGANIZATIONAL AND MANAGEMENT INFORMATION

1.16.1 AIRCRAFT OPERATOR INFORMATION

Ethiopian Airlines:

Founded: December 21, 1945

Starting date of operation: April 08, 1946

Ownership: Government of Ethiopia (100%)

Global Alliance: Star Alliance member since 2011

Head Office: Bole International Airport, P.O. Box 1755, Addis Ababa, Ethiopia

Ethiopian Airlines operates a total of 107 aircrafts consisting of: 10 A350-900, 19 B787-8, 4 B787-9, 15 B777-200 (including 9 CGO freighters), 4 B777-300, 7 B767-300, 19 B737-800 (including 2 CGO freighters), 4 B737-700, 5 B737-8MAX (including the accident aircraft) and 20 Q-400.

1.16.2 OPERATION MANUAL EXTRACTS

1.16.2.1 ETHIOPIAN AIRLINES AIRCRAFT FLIGHT MANUAL (AFM)

A check of the AFM provided by Ethiopian Airlines showed that the airline had incorporated the revisions A180625 on November, 11 2018 required by Airworthiness Directive 2018-23-51. The two pages from the AFM are in Appendix .

1.16.2.2 FCOM BULLETIN ISSUED BY BOEING TO ETHIOPIAN AIRLINES

An FCOM bulletin issued by Boeing to Ethiopian Airlines (ETH-12) regarding uncommanded nose-down stabilizer trim required Ethiopian Airlines to insert the bulletin in their B737MAX FCOM. The US Ops/hp technical advisors were provided an electronic copy of the Airline's B737MAX FCOM, and the bulletin was found to be incorporated per Boeing directions.

The bulletin is shown in Appendix 4

2 INITIAL FINDINGS

On the basis of the initial information gathered during the course of the investigation, the following facts have been determined:

- The Aircraft possessed a valid certificate of airworthiness;
- The crew obtained the license and qualifications to conduct the flight;
- The takeoff roll appeared normal, including normal values of left and right angle-of-attack (AOA).
- Shortly after liftoff, the value of the left angle of attack sensor deviated from the right one and reached 74.5 degrees while the right angle of attack sensor value was 15.3 degrees; then after; the stick shaker activated and remained active until near the end of the flight.
- After autopilot engagement, there were small amplitude roll oscillations accompanied by lateral acceleration, rudder oscillations and slight heading changes; these oscillations also continued after the autopilot disengaged.
- After the autopilot disengaged, the DFDR recorded an automatic aircraft nose down (AND) trim command four times without pilot's input. As a result, three motions of the stabilizer trim were recorded. The FDR data also indicated that the crew utilized the electric manual trim to counter the automatic AND input.
- The crew performed runaway stabilizer checklist and put the stab trim cutout switch to cutout position and confirmed that the manual trim operation was not working.

3 SAFETY ACTIONS TAKEN

The day of the accident, the operator decided to suspend operation of B737-8MAX.

On 14th March 2019, Ethiopian Civil Aviation Authority issued NOTAM regarding "The operation of Boeing B737-8 'MAX' and Boeing B737-9 'MAX' aircraft from, into or over the Ethiopian airspace, which is still active at the date of this report publication.

4 SAFETY RECOMMENDATIONS

- Since repetitive un-commanded aircraft nose down conditions are noticed in this preliminary investigation, it is recommended that the aircraft flight control system related to flight controllability shall be reviewed by the manufacturer.
- Aviation Authorities shall verify that the review of the aircraft flight control system related to flight controllability has been adequately addressed by the manufacturer before the release of the aircraft to operations.

5 APPENDICES

APPENDIX 1

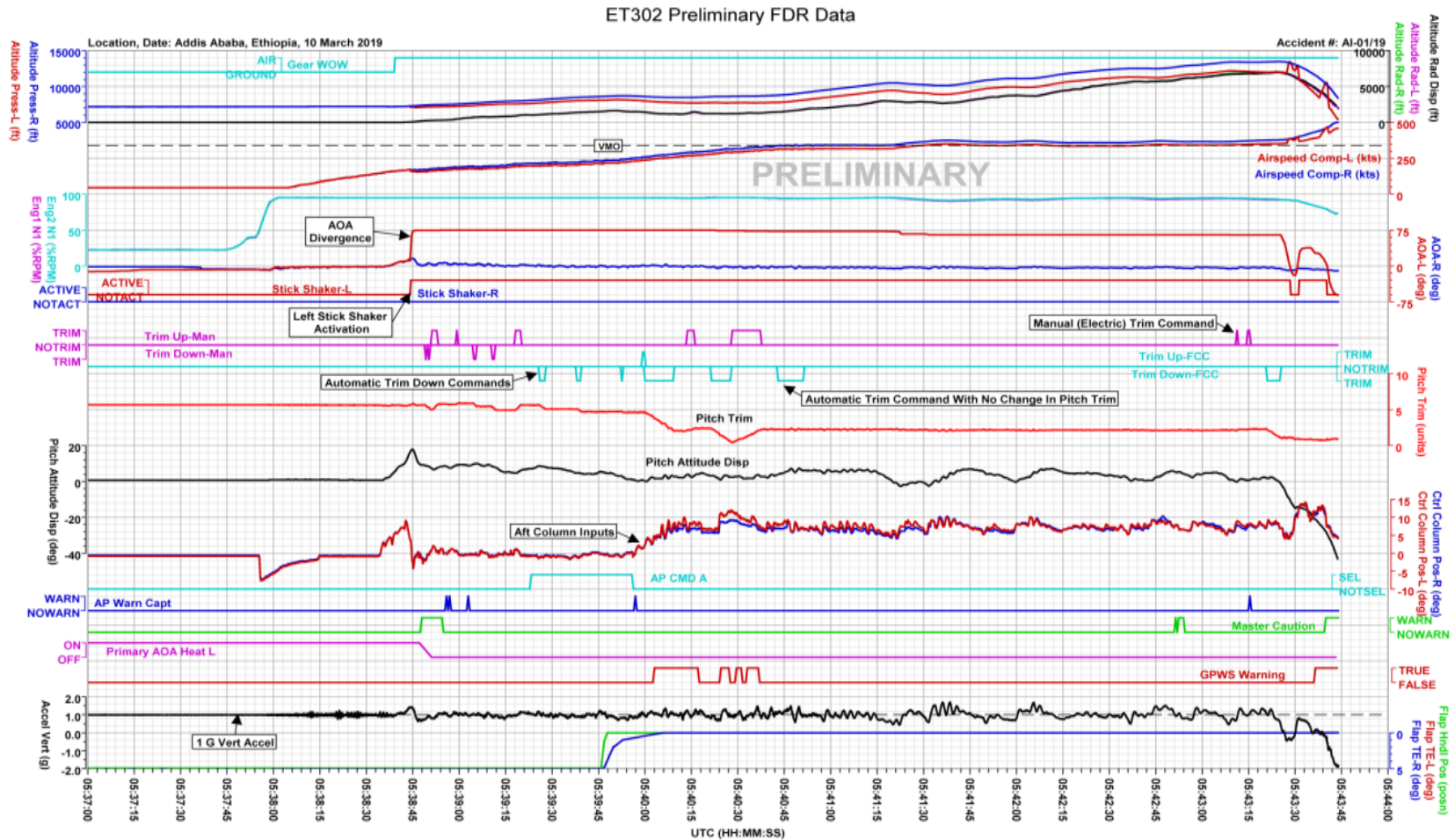

General Overview of Flight

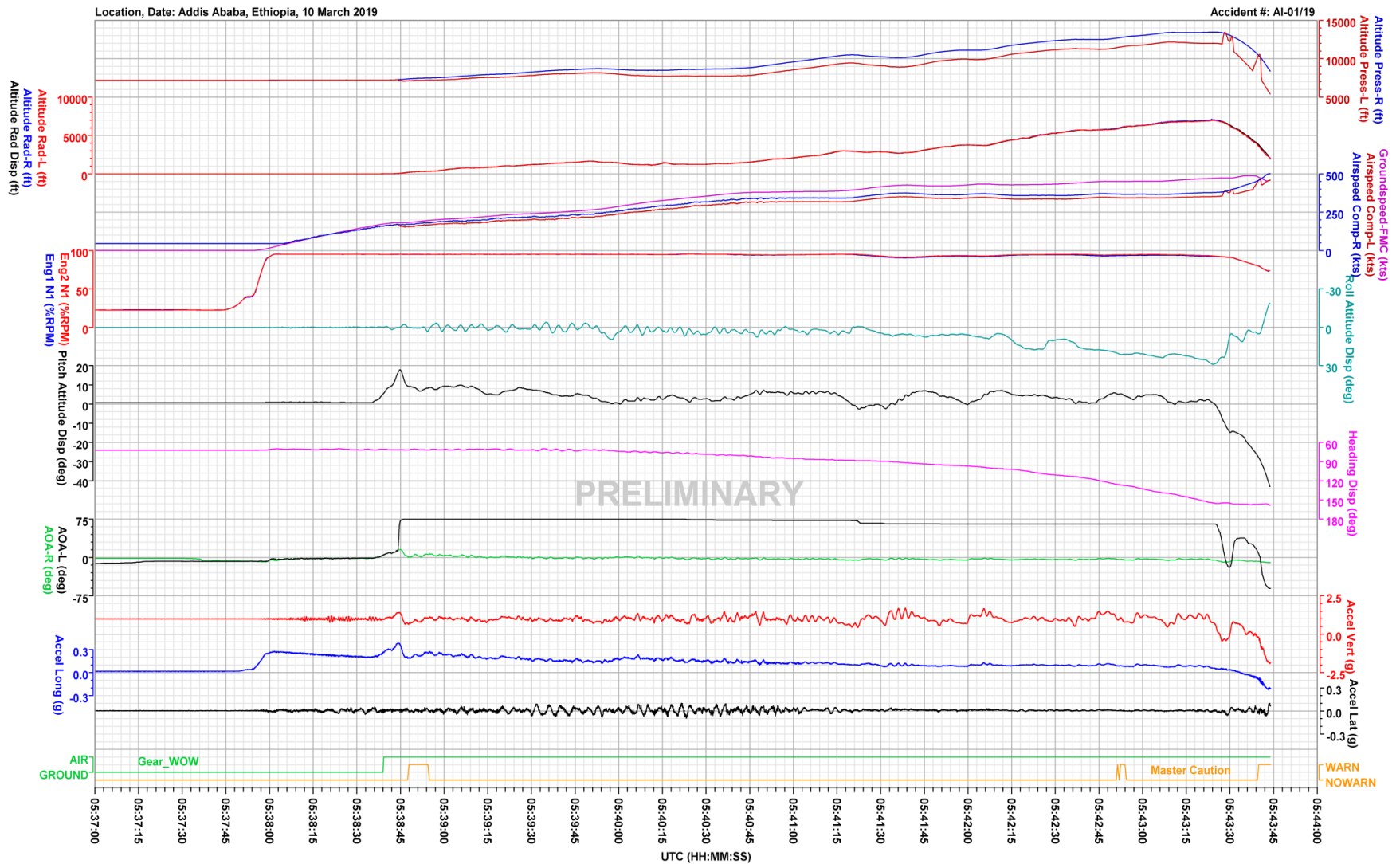

Revised: 24 March 2019

Ethiopian Airlines, Boeing 737MAX-8, ET302, ET-AVJ

Ethiopian Accident Investigation Bureau

APPENDIX 2

Certificate
Limitations**Required Crew****A163052**

Required flight crew: Two Pilots

Runaway Stabilizer**A180625***(Required by AD 2018-23-51)*

In the event of an uncommanded horizontal stabilizer trim movement, combined with any of the following potential effects or indications resulting from an erroneous Angle of Attack (AOA) input, the flight crew must comply with the Runaway Stabilizer procedure in the Operating Procedures chapter of this manual:

- Continuous or intermittent stick shaker on the affected side only.
- Minimum speed bar (red and black) on the affected side only.
- Increasing nose down control forces.
- IAS DISAGREE alert.
- ALT DISAGREE alert.
- AOA DISAGREE alert (if the option is installed)
- FEEL DIFF PRESS light.
- Autopilot may disengage.
- Inability to engage autopilot.

Speedbrake Deployment**A170119**

In flight, do not extend the speed brake lever beyond the FLIGHT detent. Do not use speed brakes below 1000 feet above the surface.

In flight, do not extend the speedbrake lever beyond the ARMED detent with flaps 40 selected.

Window Heat Inoperative**A170119**

Airspeed is limited to 250 knots IAS at altitudes below 10,000 feet with number 1 or number 2 window heat inoperative.

Wing Thermal Anti-Ice System (Ground Operation)**A163052**

Do not use wing anti-ice as a substitute for ground de-icing/anti-icing and inspection procedures which are necessary to comply with operating rules.

Do not operate wing anti-ice on the ground when the OAT is above 10°C (50°F).

**Runaway Stabilizer****A180625***(Required by AD 2018-23-51)*

Disengage autopilot and control airplane pitch attitude with control column and main electric trim as required. If relaxing the column causes the trim to move, set stabilizer trim switches to CUTOUT. If runaway continues, hold the stabilizer trim wheel against rotation and trim the airplane manually.

Note: The 737-8/-9 uses a Flight Control Computer command of pitch trim to improve longitudinal handling characteristics. In the event of erroneous Angle of Attack (AOA) input, the pitch trim system can trim the stabilizer nose down in increments lasting up to 10 seconds.

In the event an uncommanded nose down stabilizer trim is experienced on the 737-8/-9, in conjunction with one or more of the indications or effects listed below, do the existing AFM Runaway Stabilizer procedure above, ensuring that the STAB TRIM CUTOUT switches are set to CUTOUT and stay in the CUTOUT position for the remainder of the flight.

An erroneous AOA input can cause some or all of the following indications and effects:

- Continuous or intermittent stick shaker on the affected side only.
- Minimum speed bar (red and black) on the affected side only.
- Increasing nose down control forces.
- IAS DISAGREE alert.
- ALT DISAGREE alert.
- AOA DISAGREE alert (if the option is installed)
- FEEL DIFF PRESS light.
- Autopilot may disengage.
- Inability to engage autopilot.

Initially, higher control forces may be needed to overcome any stabilizer nose down trim already applied. Electric stabilizer trim can be used to neutralize control column pitch forces before moving the STAB TRIM CUTOUT switches to CUTOUT. Manual stabilizer trim can be used before and after the STAB TRIM CUTOUT switches are moved to CUTOUT.

APPENDIX 3



737 Flight Crew Operations Manual

9.1

Runaway Stabilizer

Condition: Uncommanded stabilizer trim movement occurs continuously.

- 1 Control column. Hold firmly
- 2 Autopilot (if engaged). Disengage

Do **not** re-engage the autopilot.

Control airplane pitch attitude manually with control column and main electric trim as needed.

- 3 Autothrottle (if engaged). Disengage

Do **not** re-engage the autothrottle.

- 4 **If** the runaway **stops** after the autopilot is disengaged:



- 5 **If** the runaway **continues** after the autopilot is disengaged:

STAB TRIM CUTOUT switches (both) CUTOUT

If the runaway **continues**:

Stabilizer trim wheel Grasp and hold

- 6 Stabilizer. Trim manually

7 Anticipate trim requirements.

- 8 **Checklist Complete Except Deferred Items**

▼ Continued on next page ▼

9.2



737 Flight Crew Operations Manual

▼Runway Stabilizer continued ▼

Deferred Items

Descent Checklist

- Pressurization LAND ALT ____
- Recall Checked
- Autobrake ____
- Landing data VREF ____, Minimums ____
- Approach briefing Completed

Approach Checklist

- Altimeters ____

Airspeed and Trim

Establish correct airspeed and in-trim condition early on final approach.

Landing Checklist

- ENGINE START switches CONT
- Speedbrake ARMED
- Landing gear Down
- Flaps ____, Green light



Boeing Proprietary. Copyright © Boeing. May be subject to export restrictions under EAR. See title page for details.

APPENDIX 4



**Flight Crew Operations Manual Bulletin
for
Ethiopian Airlines**

The Boeing Company
Seattle, Washington 98124-2207



Number: ETH-12

IssueDate: November 6, 2018

Airplane Effectivity: 737-8 / -9

Subject: Uncommanded Nose Down Stabilizer Trim Due to Erroneous Angle of Attack (AOA) During Manual Flight Only

Reason: To Emphasize the Procedures Provided in the Runaway Stabilizer Non-Normal Checklist (NNC).

Information in this bulletin is recommended by The Boeing Company, but may not be FAA approved at the time of writing. In the event of conflict with the FAA approved Airplane Flight Manual (AFM), the AFM shall supersede. The Boeing Company regards the information or procedures described herein as having a direct or indirect bearing on the safe operation of this model airplane.

THE FOLLOWING PROCEDURE AND/OR INFORMATION IS EFFECTIVE UPON RECEIPT

Background Information

The Indonesian National Transportation Safety Committee has indicated that Lion Air flight 610 experienced erroneous AOA data. Boeing would like to call attention to an AOA failure condition that can occur **during manual flight only**. This bulletin directs flight crews to existing procedures to address this condition.

In the event of erroneous AOA data, the pitch trim system can trim the stabilizer nose down in increments lasting up to 10 seconds. The nose down stabilizer trim movement can be stopped and reversed with the use of the electric stabilizer trim switches but may restart 5 seconds after the electric stabilizer trim switches are released. Repetitive cycles of uncommanded nose down stabilizer continue to occur unless the stabilizer trim system is deactivated through use of both STAB TRIM CUTOUT switches in accordance with the existing procedures in the Runaway Stabilizer NNC. It is possible for the stabilizer to reach the nose down limit unless the system inputs are counteracted completely by pilot trim inputs and both STAB TRIM CUTOUT switches are moved to CUTOUT.

Boeing Proprietary. Copyright © Boeing. May be subject to export restrictions under EAR. See title page for details.

February 21, 2019

D6-27370-MAX-ETH

B-12 Page 1 of 2

Flight Crew Operations Manual Bulletin No. ETH-12 , Dated November 6, 2018 (continued)

Additionally, pilots are reminded that an erroneous AOA can cause some or all of the following indications and effects:

- Continuous or intermittent stick shaker on the affected side only.
- Minimum speed bar (red and black) on the affected side only.
- Increasing nose down control forces.
- Inability to engage autopilot.
- Automatic disengagement of autopilot.
- IAS DISAGREE alert.
- ALT DISAGREE alert.
- AOA DISAGREE alert (if the AOA indicator option is installed)
- FEEL DIFF PRESS light.

Operating Instructions

In the event an uncommanded nose down stabilizer trim is experienced on the 737-8 /-9, in conjunction with one or more of the above indications or effects, do the Runaway Stabilizer NNC ensuring that the STAB TRIM CUTOUT switches are set to CUTOUT and stay in the CUTOUT position for the remainder of the flight.

Note: Initially, higher control forces may be needed to overcome any stabilizer nose down trim already applied. Electric stabilizer trim can be used to neutralize control column pitch forces before moving the STAB TRIM CUTOUT switches to CUTOUT. Manual stabilizer trim can be used after the STAB TRIM CUTOUT switches are moved to CUTOUT.

Administrative Information

Insert this bulletin behind the Bulletin Record page in Volume 1 of your Flight Crew Operations Manual (FCOM). Amend the FCOM Bulletin Record page to show bulletin ETH-12 "In Effect" (IE).

This Bulletin remains in effect until Boeing provides additional information on system updates that may allow this Bulletin to be canceled.

Please send all correspondence regarding Flight Crew Operations Manual Bulletin status, to the 737 Manager, Flight Technical Data, through the Service Requests Application (SR App) on the MyBoeingFleet home page.