



On the Flight Deck, Lighting Must Satisfy A Variety of Needs

Lighting color and intensity must be selected carefully to ensure that flight crewmembers are able to obtain information from instrument-panel displays and navigational charts and to perform other visual tasks that require uniform illumination and adequate contrast without glare.

—
*Clarence E. Rash
Sharon D. Manning*

A primary design concern on the flight deck is the illumination of instrument-panel displays and controls. Pilots must be able to see the instrument panel day and night, in a variety of ambient lighting conditions.

During the day, flight deck lighting must provide suitable brightness (illumination) for the required tasks, uniform illumination without glare, adequate contrast between information and background, and acceptable color rendition.¹

At night and during other periods of low illumination, flight deck lighting must provide a minimum level of illumination to allow pilots to obtain information from instrument-panel displays, to select switches and controls, to read navigation charts and to perform a number of visual tasks outside the flight deck (e.g., locate landmarks; scan for other aircraft; and detect and identify obstacles, towers and runway lights). This combination of requirements to acquire visual information inside and outside the flight deck, often simultaneously, can cause conflicts in the design of crew station lighting.²

Crew-station-lighting devices and systems are classified by the Aerospace Lighting Institute into the following seven categories:³

- Standard instrument and display illumination has the lighting source embedded in (or integral to) the instrument



or display. The illumination is required to read the flight information provided by the instruments and displays;

- Control-panel illumination is required for locating and adjusting switch handles, control knobs and counters;
- Illuminated push-button switches (and other types of switches) are self-illuminated for quick, easy access;
- Caution/warning indicators have many forms and shapes and are illuminated only under specific conditions. Color is used to attract the pilot's attention to convey important and time-critical information. Intensity levels are selected to attract attention but should not overpower or continually distract the pilot (especially at night);
- Instrument-panel floodlights are used for preflight checks and post-flight checks, as backup lights in case of a primary lighting system failure, and as an adjunct to the primary lighting system;
- Thunderstorm floodlights provide emergency flight deck illumination in the event that lightning at night destroys the pilot's dark adaptation, inhibiting the ability to read instruments. Thunderstorm floodlights should illuminate

the instrument panel, flight controls and floor of the flight deck; and,

- Utility lights include an assortment of auxiliary lights that may be useful for performing various tasks. Examples include map lights and flashlights.

As aircraft have become more complex, the sophistication of lighting and displays has increased (see “Earliest Cockpit Lights Were Borrowed From Tractors”). Most multi-engine aircraft have crew stations with lighting integrated into the instruments and displays. Instrument panels typically are constructed of plastic and are illuminated with miniature embedded lamps.⁴

Earliest Cockpit Lights Were Borrowed From Tractors

When manned powered flight began with the Wright brothers in December 1903, flight was a daytime venture. There were no lights in the cockpit. Only after pilots began routinely flying aircraft at night — as a result of the U.S. Post Office’s decision in the 1920s to use airplanes for mail delivery — was there a recognition of the need for cockpit lighting.¹

The first attempts at cockpit illumination involved lights that were removed from farm tractors and were mounted in the open cockpits of the biplanes that carried the U.S. mail.² These lights were powered by automobile batteries, which were removed periodically from the airplanes for recharging.

Most aircraft lacked electrical systems to power instruments, and night flights were conducted using ground beacons for navigation.³ During the 1930s, as airplanes became more sophisticated, the need for monitoring instruments increased, along with the need for lighting to enable pilots to read the instruments at night.

The first significant lighting system consisted of ultraviolet (UV) light used on the indicia (legends, characters, etc.) of the needles on dials that were painted with luminescent paint;⁴ the UV light made the indicia glow. This use of UV light was common before and during World War II.

During World War II, however, pilots on bomber missions that sometimes exceeded 15 hours to 20 hours reported visual illusions — of instruments that appeared to change in size, instrument needles that appeared to fade and instrument faces that appeared to go blank — that were attributed to the use of the luminescent paint. During the 1950s, UV lights were replaced with incandescent lamps known as “postlights” that were mounted on the instrument panel. Each postlight consisted of an incandescent lamp inside a small cylindrical tube with a cap; a slit in the tube allowed light to illuminate the dials.⁵

During the 1960s and 1970s, full instrument panels were introduced, and color was added for warning lights and caution lights. As more dials and displays were added, the cockpit instrument panel became overcrowded.

In response to the crowding of the instrument panel, a new concept of crew-station lighting was suggested using a display that produced its own lighting rather than a dial or gauge that was illuminated by a separate light source. Attempts were made to introduce cathode-ray tubes (CRTs; vacuum tubes in which a beam of electrons is projected onto a phosphorescent screen to produce a luminous spot at a

point on the screen determined by the effect on the electron beam of a variable magnetic field within the tube)⁶ in place of standard dials; inadequate contrast and poor readability were problems during day operations, even when hoods were used to prevent direct sunlight from striking the CRTs. Advances in narrow-band phosphors (a luminescent substance that emits light when excited by radiation) in the 1970s finally made CRTs acceptable cockpit displays.

The first use of color CRTs in the cockpit was demonstrated to the U.S. Air Force in the 1970s.⁷

In the 1980s, CRTs began to be replaced by liquid crystal displays (LCDs), defined as backlit displays that consist of segments of a liquid crystal material whose reflectivity or transmission varies according to the voltage applied to them.⁸◆

— Clarence E. Rash
Sharon D. Manning

Notes

1. Patzer, N. *A Light in the Sky: A Biography of Warren G. Grimes and a History of Aviation Lighting*. Urbana, Ohio, U.S.: Michael Major/Main Graphics. 1996.
2. Godfrey, G.W. Personal communication with Rash, Clarence E. July 10, 2003.
3. NAJACO Publishing. *The Indestructible Pilot: Questions and Answers in the World of Aviation*. Saudi Arabia: NAJACO Publishing, 2003.
4. Ibid.
5. Godfrey.

The postlight design is attributed to Warren G. Grimes, a pioneer in aviation lighting. Grimes designed the interior lighting for the Ford Trimotor aircraft for the Ford Motor Co. and the instrument panel lights for the U.S. Mercury, Gemini and Apollo spacecraft. In 1933, he started Grimes Manufacturing Co., now Grimes Aerospace.
6. *Merriam-Webster Dictionary*. <www.m-w.com>. Sept. 16, 2003.
7. Patzer.
8. Wallace, L. “Airborne Trailblazer: Two Decades with NASA Langley’s 737 Flying Laboratory.” U.S. National Aeronautics and Space Administration (NASA) Langley Research Center. <<http://oea.larc.nasa.gov/trailblazer/SP-4216/Intro.htm>>. July 10, 2003.

Human Vision Determines Lighting Designs

Crew-station-lighting designs are determined by the choices of light sources and their intended use on the flight deck and by the strengths and limitations of the human visual system. The recommended values of the lighting design factors provided in specifications and guidelines are based on the performance of the human visual system, including the following:

- Visual acuity is the eye's ability to resolve spatial detail. On a typical flight deck, pilots must be able to read dials, controls, switches, displays and all associated information from a working distance of between 24 inches and 36 inches ((61 centimeters and 91 centimeters).⁵
- Contrast sensitivity is the eye's ability to perceive differences in luminance. If contrast is too low, the information on the instrument, switch or control will not be perceived. The threshold contrast detection characteristics of the human eye have been quantified in a number of vision studies⁶ and are affected by a number of factors, including spatial resolution of the information (the amount of detail that can be seen), display luminance, viewing duration and the adaptation level of the viewer. As a result, requirements for minimum contrast values may vary among lighting and display configurations;⁷
- Luminance sensitivity is the eye's ability to process images in different levels of illumination. In low light, the rods — one of two sets of light-sensitive receptors in the retina, the eye's innermost lining — are responsible for vision. This is called scotopic vision. As the illumination level increases, the cones — the other set of receptors — begin to contribute to vision, along with the rods. This is mesopic vision. As the illumination level continues to increase, the rods become saturated (rod output no longer increases as luminance increases) and the cones dominate the visual process. This is photopic vision;⁸
- Color discrimination is the eye's ability to differentiate between colors. Because the cones are responsible for color perception, color discrimination begins as the cones begin to contribute to vision as an element of mesopic vision and is optimized with photopic vision. (Visual acuity also is optimized with photopic vision.); and,
- Dark adaptation is the eye's ability to adjust to ambient lighting conditions. As the ambient illumination level decreases, the pupil (the black area in the center of the eye) dilates to allow more light to enter the eye. The diameter of the pupil can expand from 0.06 inch (1.5 millimeters) to 0.3 inch (8.0 millimeters) in five minutes to 10 minutes; when the pupil is fully dilated, the eye is 50 times to 100 times more sensitive to light. After about 30 minutes in darkness, the eye achieves near-maximum dark adaptation

and is about 100,000 times more sensitive to light than it is in daylight. (This aspect of dark adaptation involves two chemicals — iodopsin in the cones, and rhodopsin in the rods — required for night vision. Light bleaches iodopsin and rhodopsin; when someone enters the dark, however, the bleaching stops, and the chemicals are restored to their maximum levels in about 30 minutes.)

The lower the starting level of illumination, the more rapidly full dark adaptation can be achieved. The rate of dark adaptation varies among individuals and is made slower by such factors as tobacco smoking, alcohol consumption, deficiencies of vitamin A and/or vitamin C, use of some medications and illegal drugs, and a lack of oxygen.

After full dark adaptation is achieved, it must be maintained (see "Optimum Vision for Flight Deck Lighting at Night," page 4). Exposure to light (landing lights, lightning or strobe lights, for example) can result in the loss of all or some level of dark adaptation; the extent of loss depends on the duration of exposure and the intensity of the light. Ten seconds of exposure to bright light can result in the loss of all adaptation; the adaptation process then must begin again and can require from five minutes to 30 minutes.

Luminance, Contrast, Glare Reduction Set Design Factors

To ensure that pilots can see instrument panel displays under all conditions, a number of design factors are considered.

One of these design factors is *luminance* (brightness, illumination). When a flight deck lighting system is energized (turned on), it must provide sufficient illumination for each instrument and its associated controls or switches to be readable. All graduations, numerals, pointers and other indicators must be legible. Except for self-luminous displays, all illuminated instrument indicators should be readable in daylight when not energized. The displays also must be legible in two diametrically opposed lighting environments: near-total darkness and daylight-illumination levels of up to 100,000 lux (9,290 footcandles), which would prevail under sunny, cloudless skies. (Light can be measured in several ways. The amount of illumination — the amount of light on a surface — typically is expressed in lux in the metric system or footcandles in the English system.)

Contrast is the measure of the difference in luminance between the information being presented and the background against which it is presented. Contrast usually is expressed as a ratio. Typical contrast values include day contrast values of 3-to-1 for alphanumeric, graphics, pictorials and video, and 4-to-1 for graphics (assuming contrast is measured against multicolored backgrounds. Night contrast values should ensure that the display is readable under night conditions with inherent flight deck illumination levels. Generally, higher contrast values are easier to achieve in dark conditions (night) than in high ambient lighting conditions (day).

The range of *dimming controls* must permit the displays to be legible under all expected ambient illumination levels. Therefore, the dimming range should be continuously variable over the entire range of the control, from “off” to “full intensity.”

Optimum Vision for Flight Deck Lighting at Night

Regardless of flight deck design, the following actions can help ensure that lighting is optimized for night flying:¹

- Ensure that all aircraft lighting (both interior and exterior, and including dimming controls) is functioning properly prior to flight;
- If a night flight is planned, wear sunglasses during the day (15 percent light transmission is recommended). This will increase the rate of dark adaptation and improve night-vision sensitivity;
- Avoid bright lights for 30 minutes immediately before a night flight;
- Just before takeoff, after the eyes have adapted to darkness, adjust the instrument lighting level so that all displays are readable. Use the minimum setting required to preserve dark-adaptation levels while maintaining the ability to see outside the flight deck;
- If a map light or utility light must be used, keep the light as dim as possible and use it for the briefest possible period;
- Because dark adaptation is an independent process in each eye, close one eye when being briefly exposed to a bright light (for example, while reading a map). This protects that eye and eliminates the need for re-adaptation;² and,
- While flying an aircraft near storm clouds, increase the level of instrument lighting to its maximum level in anticipation of lightning flashes.◆

— Clarence E. Rash
Sharon D. Manning

Notes

1. Heiler, J. *Night VFR Part 1 — Do You See the Hazard?* Transport Canada Aviation Safety Letter 4/2000. <www.tc.gc.ca/civilaviation/systemsafety/newsletters/tp185/4-00/216.htm>. July 12, 2003.
2. U.S. Army. Training Circular TC 1-204. *Night Flight Techniques and Procedures*. Washington, D.C., U.S.: Department of the Army, 27 December 1988.

The control should provide multiple-stepped or continuously variable illumination. Abrupt or extreme changes in illumination levels should be avoided.⁹

Lights must be positioned to provide optimal illumination without causing direct *glare* or indirect glare that interferes with viewing, either inside or outside the flight deck. Glare is distracting and annoying and is a factor in eye fatigue. Glare reduces the contrast of objects near the glare source, making them difficult to see. Visual acuity also is reduced in the presence of glare. Sensitivity to glare increases with age.¹⁰

Internal reflections from the canopy, windshield and side windows should be minimized. Such reflections cause confusion by presenting duplicate images of instruments and interfering with external viewing. Adjusting the level of the instrument lighting can eliminate some reflections. Another technique involves the installation of hoods or glare shields, which also can reduce glare.

A common and often overlooked design factor is luminance *uniformity* (or balance) across the crew station. A lack of uniform intensity in displayed and illuminated information can prevent a pilot from observing critical data on a display. Observing different levels of luminance (or illumination) during normal periodic visual scans of the flight instruments can be distracting. Luminance uniformity and balance should be maintained over the dimming range of the displays.

Although the human eye is not sensitive to differences in luminance across large areas, it is sensitive to abrupt changes (discontinuities or edges) in lighting levels. A typical recommendation is that luminance uniformity may vary by plus or minus 20 percent within any quadrant of a large-area display and by plus or minus 40 percent across the entire display. Because abrupt changes in uniformity are distracting, small-area uniformity should allow variations of no more than plus or minus 10 percent. The Society of Automotive Engineers (SAE) aerospace recommended practice for transport category aircraft says that a high-to-low brightness ratio across an entire display should not be greater than 3-to-1 (a 33 percent variation).¹¹

Color in displays and various indicator lamps can present additional information without added space requirements. Specialists in color vision and avionic displays have reached a consensus on some aspects of the use of color in flight deck displays. For example, the SAE aerospace recommended practice calls for a “conservative and consistent use of color, using no more than six color codes for symbols: red, yellow (amber), green, white, magenta and cyan [greenish-blue], while reserving red and yellow for warnings and cautions.”¹² The selection of these colors was intended to minimize confusion and to address such factors as color discrimination, search performance (the ability to search for and to locate switches and other items on the instrument panel) and the

ability to associate a maximum number of colors with functional attributes.

Red is used to warn the pilot of a hazardous condition or when some system (or some portion of a system) that affects safety of flight is inoperative and some critical corrective action or override is required. Examples of indicators that should be red include “Fire” and “Fuel Low.” Flashing red has been used to warn of emergency conditions that require urgent action by the pilot to avert serious impending damage or injury.

Yellow is used to bring to the pilot’s attention a condition that may affect the successful continuation of the flight. Examples include “Autopilot out” and “Radar out.”

Green is used to indicate the active status and satisfactory operation of a monitored system (e.g., “Pitot Heat”). White is used to indicate system conditions that do not have correct or incorrect implications (e.g., selection of the “Intercom” system). Magenta and cyan are used in a number of displays, including map presentations on multi-function displays (MFDs).

Bright sunlight (which typically is measured at 60,000 lux to 70,000 lux [5,574 footcandles to 6,503 footcandles]) can interfere with the *sunlight readability* of flight deck displays, switches and indicators — that is, the pilots’ ability to observe the displays in conditions of bright sunlight. The worst effect of bright sunlight is the reduction of display contrast that results from adding the bright sun illumination to both the display information and the background (the ratio of which defines the contrast). For the relatively low levels of lighting used on flight decks, if a display were subjected to a 60,000-lux illumination, the contrast ratio would be approximately 1-to-1, with virtually no differentiation between a light source and its background.

High ambient lighting conditions also cause the Abney effect, in which — except for yellow and some blues — adding large amounts of white light causes a shift in the perceived hue and can result in a desaturation of color.¹³

Light Classifications Based on Source

Light usually is generated by one of two physical processes: incandescence or luminescence. Incandescence is the heating of a material until it produces visible energy (glows). Incandescent light energy is broadband (includes light over a wide range of wavelengths) and is a function of the temperature of the material. Luminescence is the name given to the types of light energy produced by excitation causes other than heating. Luminescence generally is categorized in terms of the type of excitation; for example, electroluminescence is excitation by electric voltage or current, chemiluminescence is excitation by chemical reaction, and photoluminescence is excitation by photons (particles of electromagnetic radiation). Light energy

from luminescence light results from energy emitted as a result of a change in energy states (usually of electrons) when the material is excited by an external source.

Most light sources on the flight deck are classified according to how the light energy is produced (Table 1, page 6).

Incandescent lamps have been used in virtually all cockpit lighting schemes for decades. Incandescent lamps operate on the basic principle that electrical current flows through a small metallic wire (filament) until the wire is heated to the point of glowing (Figure 1, page 6).

Modern incandescent lamps used in crew-station lighting are similar in size to those used in flashlights and are referred to as miniature lamps. They consist of a tungsten filament within a glass envelope containing a vacuum or inert gas, all of which is attached to a base.

To produce visible light energy, the lamp filament temperature must exceed 727 degrees Celsius (C; 1,340 degrees Fahrenheit [F]). Exceeding this threshold temperature will increase the proportion of emitted energy that is visible (useful). The light energy of incandescent lamps usually is compared with the theoretical energy output of a “blackbody” (a perfect emitter or absorber of energy). Therefore, lamps often are identified by the color temperature of the blackbody that their output most closely matches. This color temperature usually is expressed in degrees Kelvin (K), with typical values between 1,700 degrees K (1,427 degrees C and 2,601 degrees F) and 2,500 degrees K (2,227 degrees C and 4,041 degrees F).

Lamps usually are defined by four basic operating characteristics: operating voltage, operating current, luminance and lifetime. Some operational requirements, such as available space and environmental conditions, also affect lamp choice for specific applications.

Typical operating voltages for instrument panel incandescent lamps range up to 48 volts, with operating currents of several hundred milliamps.

Another important lamp characteristic is its efficiency in turning electric current into light energy. The efficiency of incandescent lamps is about 5 percent to 10 percent, which means that only 5 percent to 10 percent of the electrical power is converted into visible light. The rest is converted into heat. Another method of expressing efficiency is by dividing the light output (measured in lumens) by the electric input (measured in watts). The resulting value, expressed in lumens per watt (LPW), is always greater than one. Typical LPW values for incandescent lamps used in flight deck lights are 12 LPW to 18 LPW. This lamp “efficiency” also is referred to as the lamp’s “efficacy.”

The intensity (brightness) output of an incandescent lamp often is defined by a unit of measure called mean spherical

Table 1
Comparison of Crew Station Lighting/Display Technologies

Lighting/display technology	Strengths	Weaknesses
Incandescent lamps	<ul style="list-style-type: none"> • Very mature technology • Full color range (with filters) • Wide viewing angle 	<ul style="list-style-type: none"> • High heat production • High power consumption • Incompatibility with night vision imaging system (NVIS)
Electroluminescent (EL)	<ul style="list-style-type: none"> • High luminous efficiency • Wide viewing angle • Thin profile • Long lifetime 	<ul style="list-style-type: none"> • Limited brightness (although improving) • Full color still under development
Light-emitting diode (LED)	<ul style="list-style-type: none"> • “Cold” light • Narrow band • Long lifetime 	<ul style="list-style-type: none"> • Limited color gamut • Moderate luminance available (but can be ganged)
Cathode ray tube (CRT)	<ul style="list-style-type: none"> • Mature technology • Full color • High resolution • Superior image quality 	<ul style="list-style-type: none"> • Bulky • Heavy • High operating voltages • High power consumption
Active-matrix liquid crystal display (LCD)	<ul style="list-style-type: none"> • Full color • Good temporal response • High image quality 	<ul style="list-style-type: none"> • Requires backlighting • Moderate power consumption • Limited operating temperature range • Moderate viewing angle
Organic light-emitting diode (OLED)	<ul style="list-style-type: none"> • High luminance • Fast response time • Thin and lightweight • Wide viewing angle 	<ul style="list-style-type: none"> • Low reliability • Immature technology • Color limitations

Note: “Cold” light refers to light that has been produced without the heating of a material such as a lamp filament.

Source: Clarence E. Rash and Sharon D. Manning

Miniature Incandescent Bulb

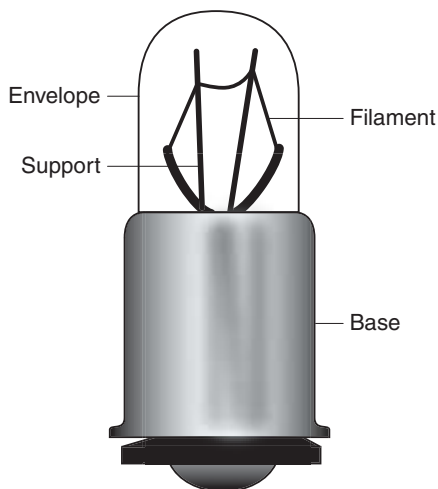

Source: Clarence E. Rash and Sharon D. Manning

Figure 1

candlepower (MSCP). The MSCP represents the average light output measured in 360 degrees. (The MSCP can be converted to lumens by multiplying by 12.57.)

Some environmental factors adversely affect incandescent lamp operation and especially the lifetime of the lamp. For example, vibration (and shock) can result in a broken filament. Vulnerability to this type of failure increases as the filament ages and becomes more brittle. Operation in high ambient temperatures (above 200 degrees F [93 degrees C]) also can reduce the lifetime of a lamp because of the increased loss of the inert gases used inside the lamp’s glass envelope.¹⁴

Overall, incandescent lamps have been an inexpensive, reasonably tough, somewhat efficient solution to flight deck lighting needs. They provide a wide range of color (with filtering) and have reasonably long lifetimes (25 hours to 500 hours). Major disadvantages include their high level of heat production, their large power requirement and their catastrophic (sudden, without warning) failure mode.

Electroluminescent Lamps Provide Even Illumination of Flat Surfaces

Electroluminescent (EL) technology was developed in the late 1930s, but EL lamps were not mass-produced until the late 1980s. EL light is produced by applying an electric field (voltage) to a layer of phosphor between two layers of conducting material, one of which is transparent. EL devices are emissive in nature; that is, they produce their own light.

Most EL lamps are less efficient (three LPW to five LPW of input power) than incandescent lamps, but their efficiency has been improved in recent years. They require operating voltages of 20 volts to 200 volts of alternating current (AC) and have limited lifetimes. Nevertheless, they are the most practical type of light source for uniform illumination of a flat area of up to several square meters. EL lamps assume the shape of the instrument or dial that must be illuminated, regardless of the complexity of the shape. They are best suited for low-light applications of less than 20 footlamberts (68 nits). (A footlambert is a measurement of luminance; a nit is its metric equivalent.)

Other advantages of EL lamps include their flexibility and thinness (typically 0.04 inch to 0.07 inch [one millimeter to two millimeters]). Because EL lamps do not produce their light from heat, they often are referred to as “cold” illumination sources. EL lamps are also impact-resistant and vibration-resistant.

Standard colors for EL lamps are white, yellow, blue, green and blue-green, but a full range of colors is possible.

Unlike most light sources, EL lamps do not exhibit catastrophic failure. Instead, they degrade (fade) over time. This implies that EL lamps will not fail in use and that they can be replaced before degrading to an unacceptable level. Lamp life usually is defined in terms of the time required for the lamp’s brightness to decrease to a percentage of its original value, usually 50 percent (half-life). Half-life values depend on the voltage and frequency of operation and the type of phosphor used. Half-life values of between 3,000 hours and 10,000 hours typically are cited in manufacturers’ literature.

Light-emitting Diodes Have Low Power Requirements, Long Lifetimes

A light-emitting diode (LED) lamp (also called a solid-state lamp) produces light when an appropriate voltage is placed across the junction of two types of semiconducting materials. The basic parts of an LED lamp include light-emitting semiconductor material (referred to as the die), a lead frame to support the die and a virtually shatterproof encapsulation epoxy that surrounds and protects the structure to withstand shock and vibration that would cause incandescent lamps to break (Figure 2).

Light-emitting Diode

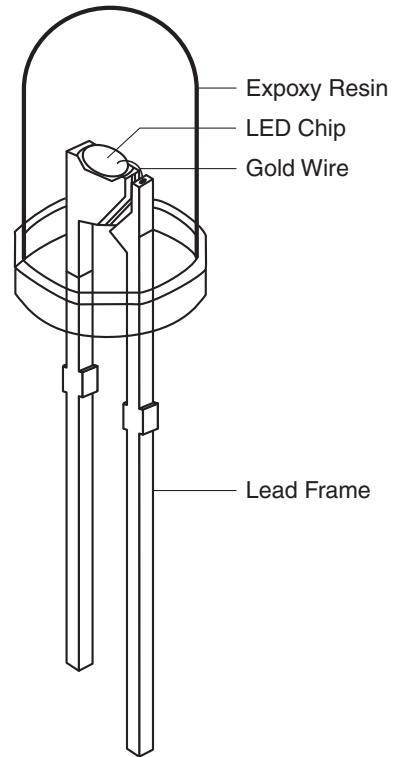

Source: Clarence E. Rash and Sharon D. Manning

Figure 2

Advantages of LEDs include compact size, low voltage and low power requirements, improved efficiency, availability in an array of colors, long life (because they have no filament to burn out), and no significant heat production (for low-brightness LEDs). Newer LEDs of one watt to five watts, however, produce significant heat and require “heat sinks” — mechanical components or materials that move heat away to prevent heat damage.

LED sizes range from subminiature (three millimeters [0.1 inch]) to jumbo (10 millimeters [0.4 inch]). Operating voltages on LEDs typically are from two volts to four volts. LEDs convert approximately 70 percent to 90 percent of the electric input power into visible light; the MSCP of LEDs is as high as 40 LPW.

A major advantage of LEDs is their ability to produce very precise colors. This is an important feature when trying to balance lighting across instrument panels. Currently, all colors from red to blue are available in LEDs in efficacies that outperform filtered incandescent lamps. Efficacies of more than 20 LPW are available for amber and red LEDs. LEDs demonstrate excellent stability of both color and intensity (brightness) for lifetimes that exceed 100,000 hours. LEDs have an extremely low failure rate under normal operating conditions.

Because of these qualities, many lighting manufacturers have designed LED lamps to replace various incandescent lamps. This is accomplished by integrating a standard LED into a package about the same size and with the same power characteristics of a specific incandescent lamp.

Until recently, LED lamps were not as bright as typical incandescent lamps. In recent years, however, LED outputs have been increased. The light output of LEDs usually is expressed in millicandela (or thousandths of a candela, an international unit for measuring luminous intensity, originally based on the light of a small flame). Values for production LEDs range from a few tenths of a millicandela to several thousand millicandela.

Some LED-powered lights may require a number of LED lamps. This can be an advantage because the failure of one LED does not result in failure of the entire light.

LEDs have one characteristic that can be both an advantage and disadvantage: They are “narrow-angle emitters” and, as such, emit light in a forward-shaped cone, which often is narrow and usually is specified in degrees, such as 7 degrees or 15 degrees. Because light is emitted in a narrow angle, the result is high-intensity lighting. Difficulty can result if LEDs are used to replace incandescent lamps, whose heated filaments are “spherical emitters,” radiating light in all directions — a desirable characteristic for good diffused illumination of a display panel.

Cathode Ray Tubes, Liquid Crystal Displays Dominate Multi-function Displays

Cathode ray tubes (CRTs), which have been available commercially since the 1930s, have been used in recent years along with flat-panel displays in “glass cockpits” in which multi-function displays (MFDs) have replaced a multitude of individual dedicated displays that once occupied virtually every square inch of instrument-panel space. MFDs were introduced to reduce the clutter of traditional flight deck designs and to provide the aircraft with enhanced capabilities that would not fit into the traditional flight deck design.¹⁵

CRTs differ functionally from other incandescent lamps and EL strips, which are used primarily as sources of illumination; that is, they produce the light needed to read information. CRTs provide the information directly — and this characteristic of customizing the presented information makes CRTs suitable in MFDs.

CRTs generate images by modulating the intensity of a scanning electron beam striking a phosphor surface on the face of the CRT. The various components of the CRT are encapsulated in a glass envelope (tube). CRTs provide high-quality imagery, full-color capability and long lifetimes.¹⁶ Touch screens fitted over the faces of CRTs provide the added flexibility of accepting

interactive commands for the selection of information to be displayed.

The image quality presented by a CRT is considered to be the best available from any display technology. CRTs provide excellent contrast, brightness and resolution. The major disadvantages of CRTs are their large size, weight and high power requirements. CRTs often degrade gradually but can fail catastrophically.

Liquid crystal displays (LCDs) also are used on modern flight decks as MFDs, to present custom information, including replicas of dials and gauges. LCDs are one of a number of displays known as flat-panel displays because of their thin profiles and flat display surfaces.

Unlike other light sources, LCDs are not inherently self-emissive. Rather, LCDs act as an array of small shutters that open and close to varying degrees to allow light from a backlight to be reflected or transmitted. LED arrays, fluorescent lights and EL panels are used by LCD manufacturers as backlights.

The mechanism by which modulation is achieved is the application of an electric field across a liquid crystal (LC) material that has both liquid and crystalline properties. The LC material is sandwiched between layers of glass and a set of polarizers. By applying an electric field, the LC can be caused to act as a light shutter, modulating the light from the backlight to form images.

There are a vast number of LC materials and almost as many techniques for producing LCDs. The various LCDs often are classified according to the method by which the individual picture elements (pixels) are activated (“addressed”). The two most commonly used addressing modes are passive matrix and active matrix. In passive-matrix LCDs, pixels are activated at the intersection of a pair of vertical electrodes and horizontal electrodes. A voltage applied to any selected pair causes the LC material at the intersection to react. Active-matrix LCDs use an array of individual pixels that are each controlled by an electronic switch.¹⁷ The most successful active-matrix approach to addressing pixels uses thin film transistors with an electric capacitor to switch each pixel on and off.

LCDs can be monochrome or full color. Monochrome LCDs usually use a backlight consisting of one or more fluorescent lamps, a reflector and a diffuser. Recently, there has been an increase in use of electroluminescent panels as backlights. Color has been achieved by a number of methods. One method uses pixels composed of three or more color subpixels. Activating combinations of these subpixels and controlling their transmission achieves a large number of colors.

The use of LCDs (especially active-matrix LCDs) as MFDs is increasingly common. Incandescent lamps will continue to be used for some time, and EL and LED lamps will continue to be used as alternative light sources.

Red Lighting Preserves Visual Sensitivity for Outside Viewing

The debate over the merits of red lighting vs. white lighting has persisted for years, ever since the search for new methods of crew-station lighting began during and after World War II.

H.K. Hartline, a physician and physiologist, found during his work with film development that he adapted well to darkness under red lighting conditions. Working for the U.S. Navy, Hartline demonstrated that red-lighted instruments were readable at low-light levels. Some of his other work with the human retina had shown that the rods are almost totally insensitive to red. As a consequence of his recommendations, the U.S. Army and U.S. Navy began using red light in their cockpits in the 1940s.¹⁸

To produce red lighting during an era when incandescent lamps were the primary light source, the light from the lamps was filtered. This increased the cost of the lighting, generated heat in the instrument panel and prompted manufacturers to question whether there was really an advantage to using red lighting in place of white lighting.

Hartline's conclusions were supported by numerous other studies on dark adaptation. In 1982, faced with the question of the compatibility of night-vision devices and crew-station lighting, the U.S. Army reviewed the issue. An Army report that compared the effects of red lighting and blue-white lighting (which uses a blue filter to compensate for an incandescent lamp's tendency to turn yellow as it is dimmed) on dark adaptation under operational conditions said, "Under conditions of total or nearly total darkness, red lighting preserves visual sensitivity for outside viewing to a greater extent than does blue-white lighting. This is true even when instrument lights are set at the low levels ... at which (U.S. Army) aviators normally set their instruments."¹⁹

Nevertheless, the report also said that with a full moon illuminating a clear sky, the difference between the two lighting schemes "vanishes."

Other studies have examined the advantages of white light. In a 1987 book, Frank Hawkins cited a number of advantages, including that white light reduces eye fatigue, improves instrument and display contrast, provides better illumination in thunderstorms and daylight, and permits effective color coding.²⁰ In red light, the color coding on some aeronautical charts and some flight instruments disappears — that is, the information is readable, but color differentiation among symbols cannot be seen.²¹

The American Optical Association said that red lighting on the flight deck requires more focusing power than white light or blue-green light for near objects to be observed clearly. This may cause difficulty especially for pilots in their 40s and

older with presbyopia — the most common age-related change in vision — in which the eyes become less able to focus on nearby objects.²²

Nevertheless, red lighting became the standard for military aircraft and some nonmilitary aircraft and functioned well until the introduction of night-vision goggles (NVGs), multicolored CRT displays and active-matrix LCD displays, which were found to be incompatible with red lighting.

Studies determined that ambient red lighting does not provide true dark adaptation but instead provides color adaptation. The rods and cones adapt to the red wavelengths; consequently, the pilot may have difficulty discriminating between some colors on the color display. Partly to address this issue, the U.S. Air Force decided to use blue-white lighting on its flight decks.²³ Most commercial aircraft use unfiltered white lighting to reduce costs. Blue-white lighting on an instrument panel requires about 30 percent more lamps than white lighting. That requires a bigger power supply, which in turn requires more weight, which decreases useful load.²⁴ Until the advent of MFDs in the 1980s, most commercial airliners used unfiltered white lighting.

In the early 1990s, the Aerospace Lighting Institute suggested the following guidelines for selecting a lighting system based on color:²⁵

- If the primary visual task is inside the flight deck, consisting of monitoring display instrumentation and controls, and the outside visual task of scanning for other aircraft takes a secondary role (without compromising safety), then a lighting system comprised basically of white lights is recommended;
- If the primary visual task is scanning for lights and other aircraft (but night-vision devices are not being used), then a lighting system comprised basically of red lights is recommended; and,
- If night-vision devices are required for flight, then both white light and red light are prohibited. A blue-green lighting system has been found to be effective in military aircraft.

These basic guidelines, although useful, have been difficult to apply because of the use of MFDs in aircraft with glass cockpits.

Today's airliners generally utilize unfiltered white light at crew stations for both panels and instruments (except flat-panel displays). For example, all current Boeing airplanes use unfiltered white light. Pilots are able to dim area lighting and instrument lighting to "appropriately low levels to allow sufficient dark adaptation for nighttime operation," said Alan R. Jacobsen, Ph.D., technical fellow, flight deck engineering, Boeing Commercial Airplanes.²⁶ Those appropriate levels were

determined by human factors evaluations. The aircraft also are equipped with storm lighting “in which the flight deck lighting can be driven to fairly bright levels with the flip of a switch” to counter the loss of dark adaptation resulting from lightning flashes, Jacobsen said.

John K. Lauber, vice president for safety and technical affairs at Airbus, said that Airbus also uses unfiltered white light on the flight decks of its airplanes.²⁷

“[Using red light to protect] night vision may have been important at one time but is probably not so significant now, with modern lighting systems, both airborne and ground-based,” Lauber said.

The U.S. Air Force uses blue-white incandescent light for both panels and instruments (except flat-panel displays) at crew stations that do not require utilization of a night vision imaging system (NVIS). A blue filter sometimes is placed over incandescent lamps to compensate for a yellowing that occurs when they are dimmed. The U.S. Navy and U.S. Army use red incandescent lighting for both panels and instruments (except when flat-panel displays are used) in aircraft where an NVIS is not used. In aircraft in which an NVIS is used, blue-green NVIS-compatible lighting is used. The blue-green lighting is required because an NVIS has a spectral sensitivity that favors the red end of the electromagnetic spectrum, including both the red region of the human visible spectrum and the invisible infrared region. This characteristic is enhanced by a blue cutoff filter that prevents virtually all blue light from being seen.

Modern corporate/business aircraft have white EL panels and incandescent instrument lighting (except when flat-panel displays are used). Most smaller general aviation aircraft are equipped with incandescent post lighting for instruments and post lighted indicia (plates) for legends and circuit breaker panels.

Night-vision Devices Rely on Blue-green Lighting

For years, the military — especially military aviators — has operated at night using night-vision viewing devices with image intensification. The better known of these night-vision aids consists of a pair of image-intensifier tubes mounted in a binocular configuration on a helmet. While using this system, the pilot looks through it to view the outside world and looks beneath and around it to view flight instruments. Originally called NVGs and later the aviator’s night-vision imaging system, the device now is referred to as NVIS.

The military used night-vision aids for ground operations during the late 1960s. Aviation-developed NVGs have been used in military aircraft since the 1970s and now are being used in civil aviation, in both rotary-wing aircraft and fixed-wing aircraft, especially in law enforcement and emergency medical services (EMS) operations. The U.S. Federal Aviation Administration

(FAA) issued the first supplemental type certificate in January 1999 to authorize use of night-vision devices by civilian EMS helicopter operators.²⁸

Using NVIS for night flight provides the flight crew with improved methods of orienting the aircraft and avoiding terrain and obstructions.²⁹ (Disadvantages, however, include reduced depth perception, neck strain, fatigue, a decrease in visual acuity, an absence of color discrimination and a reduced field of view.)

Image intensifiers amplify reflected or emitted light so the eye can more readily see a poorly illuminated scene. These devices depend on the presence of a minimum amount of light to produce a usable image. This is analogous to using a microphone, amplifier and speaker to allow the ear to more easily hear a faint sound. The intensified image resembles a black and white television image but in shades of green (caused by the selected display phosphor) instead of shades of gray.³⁰

Using the principle of image intensification, an NVIS multiplies (amplifies) the few photons present at low ambient light levels into a larger number seen by the user. The multiplication factor is typically 6,000 to 8,000.

The use of an NVIS on the flight deck presents lighting designers with a dilemma. The primary purpose of an NVIS is to allow the pilot to see the outside world. An NVIS has an “automatic gain control” that reacts to the ambient light level. If the ambient light level decreases, the gain control increases the multiplication factor; if the ambient light level increases, the gain control decreases the multiplication factor.

The dilemma is that an NVIS must respond to the ambient lighting level outside the flight deck but cannot differentiate between light (photons) originating outside the cockpit (the desired response) and light originating inside the cockpit (i.e., light from the display instruments). Therefore, the lighting designer must illuminate the cockpit with light that will allow the pilot to clearly view the instruments through the NVIS but will not cause the NVIS to lower its performance in amplifying the low-light scenes outside the aircraft.

The military has attempted to overcome this problem by developing a blue-green (no red) lighting system that uses the unique spectral response of NVIS. The blue-green light is visible to the human eye beneath the NVIS, allowing the pilot to view the instruments, but is virtually invisible to the NVIS and does not adversely affect performance. The pilot can optimally perform both the required internal visual tasks and external visual tasks.

Until the recent introduction of alternative light sources, flight deck lighting consisted totally of incandescent lamps. A substantial part of emissions from these lamps is in the near-infrared region of the electromagnetic spectrum — the most sensitive portion of the NVIS response. The acceptable

blue-green lighting system was achieved by the use of special filters capable of blocking almost all of the red and infrared energy of the incandescent lamp.

The blue-green lighting scheme was a satisfactory solution to the main function of crew station lighting (e.g., visibility of dials, switches and other items). Nevertheless, red warning lights and yellow caution lights are an additional NVIS lighting challenge. To retain the color function of these lights, they cannot be made completely compatible with NVIS.³¹

If an NVIS is used, the pilot's eyes usually function in the low photopic-mesopic region of vision. After the NVIS is removed, complete dark adaptation is regained in three minutes to five minutes. This is because the average light levels associated with NVIS do not completely bleach the eye's rhodopsin.

New Light Sources Foster Panoramic Flight Displays

Although glass cockpits retain a few dedicated instruments requiring separate lighting, LED light sources or EL light sources increasingly are replacing traditional incandescent lamps.

Newer light sources also are being developed, including the organic (carbon-based) light-emitting diode (OLED), which consists of a series of organic thin films between two conductors. When electrical current is applied, bright light is emitted. This process is electrophosphorescence. OLEDs, which could be available on flight decks within three years and could become commonplace within a decade, are self-luminous, require no backlights and will provide high luminance and low-power displays that are only thousandths of an inch (or millimeter) thick. OLEDs also have the potential to be used as flexible displays that can be bent, twisted or rolled into various shapes. Lighting specialists believe that OLEDs may make possible panoramic flight deck displays.³²

The types of lighting used on the flight deck differ according to a number of factors, including the requirements of the human visual system and the purpose of the flight. The color of flight deck lighting and its intensity should be chosen to ensure that flight crewmembers are able to obtain information from instrument panel displays and navigational charts and to perform other visual tasks.♦

George W. Godfrey of the Aerospace Lighting Institute, Clearwater, Florida, U.S., contributed to the research and preparation of this report.

Notes

1. Godfrey, G.W. *Principles of Display Illumination Techniques for Aerospace Vehicle Crew Stations*. Tampa, Florida, U.S.: Aerospace Lighting Institute, 1991.

2. Ibid.
3. Ibid.
4. Illuminating Engineering Society of North America (IES). *IES Lighting Handbook*, edited by J.E. Kaufman. New York, New York, U.S.: Illuminating Engineering Society of North America, 1984.
5. Mittelman, M.H. *Eye Exams and Aviation: Prescription for Success*. American Optical Association. <www.aoa.org>. July 9, 2003.
6. IES.
7. Klymenko, V.; Harding, T.; Martin, J.; Beasley, H.; Rash, C. *Image Quality Figures of Merit for Contrast in CRT and Flat-panel Displays*, USAARL Report No. 97-17. Fort Rucker, Alabama, U.S.: U.S. Army Aeromedical Research Laboratory, 1997.
8. Kaiser, P.K. *The Joy of Visual Perception: A Web Book*. <www.yorku.ca/eye/toc-sub.htm>. 1996.
9. General Aviation Manufacturers Association. *Recommended Practices and Guidelines for Part 23 Cockpit/Flight Deck Design*. Washington, D.C., U.S.: General Aviation Manufacturers Association, September 2000.
10. Hawkins, F. "Vision and Visual Illusions." Chapter 5, *Human Factors in Flight*. Brookfield, Vermont, U.S.: Gower Publishing Co., 1987.
11. Society of Automotive Engineers (SAE). *Flight Deck Lighting for Commercial Transport Aircraft*. Aerospace Recommended Practice ARP4103. Warrendale, Pennsylvania, U.S.: Society of Automotive Engineers Aerospace, 2003.
12. SAE. *Human Engineering Considerations in the Application of Color to Electronic Aircraft Displays*. Aerospace Recommended Practice ARP4032. Warrendale, Pennsylvania, U.S.: Society of Automotive Engineers Aerospace, 1988.
13. Prasad, G.K.G. "Vision in Glass Cockpit." In *Optics and Refraction: 60th Annual Conference of All India Ophthalmological Society*, edited by N.S.D.Raju. Ahmedabad, India. 2002.
14. Godfrey.
15. Silverio, F. J.; Drennen, T. G. "Advanced Cockpits for Battlefield Helicopters — A Sikorsky Perspective." A paper presented at the Eleventh European Rotorcraft Forum, London, England. Sept. 10–13, 1985.
16. Leher, N.H. "The Challenge of the Cathode-ray Tube." In *Flat-panel Displays and CRTs*, edited by L.E. Tannas. New York, New York, U.S.: Van Nostrand Reinhold, pp. 138-176. 1985.
17. Penz, P.A.; Tannas, L.E. "Non-emissive Displays." In *Flat-panel Displays and CRTs*, edited by L.E. Tannas. New York, New York, U.S.: Van Nostrand Reinhold, pp. 415-452. 1985.
18. Godfrey, G.W. Personal communication with Rash, Clarence E., and Manning, Sharon D. July 10, 2003.
19. Holly, F.F.; Rogers, V.R. *Direct and Neighboring Sensitivity Changes Produced by Red and Blue-white Adapting Fields*, USAARL Report No. 82-1. Fort Rucker, Alabama, U.S.: U.S. Army Aeromedical Research Laboratory, 1982.

20. Hawkins.
21. Jacobsen, Alan R. E-mail correspondence with Werfelman, Linda. Alexandria, Virginia, U.S., Oct. 27, 2003. Flight Safety Foundation, Alexandria, Virginia, U.S.
22. Mittelman.
23. Tredici, T.J. "Aerospace Ophthalmology," Chapter 8, *Air Force Flight Surgeon Guide*. Brooks Air Force Base, Texas, U.S.: USAF School of Aerospace Medicine. <wwwsam.brooks.af.mil/af/files/fsguide/HTML/Chapter_08.html>. July 9, 2003.
24. NAJACO Publishing. *The Indestructible Pilot: Questions and Answers in the World of Aviation*. Saudi Arabia: NAJACO Publishing, 2003.
25. Godfrey. *Principles of Display Illumination Techniques for Aerospace Vehicle Crew Stations*.
26. Jacobsen.
27. Lauber, John K. E-mail correspondence with Werfelman, Linda. Alexandria, Virginia, U.S., Nov. 3, 2003. Flight Safety Foundation, Alexandria, Virginia, U.S.
28. Salazar, G.J.; Nakagawara, V.B. *Night Vision Goggles in Civilian Aviation*. <www2.faa.gov/avr/afs/news/archive/mayjune/Goggles.htm>. July 12, 2003.
29. Bower, R.; Bower, S. "Being Green — Then Seeing Green." *Aviation Today*, February 2003 <www.aviationtoday.com/reports/rotorwing/previous/0203/0203nvg.htm>. July 12, 2003.
30. Verona, R.; Rash, C. *Human Factors and Safety Considerations of Night Vision Systems Flight*. USAARL Report No. 89-12. Fort Rucker, Alabama, U.S.: U.S. Army Aeromedical Research Laboratory, 1989.
31. In the United States, during most of the development period of night vision imaging system (NVIS)-compatible lighting, requirements were defined by Military Specification MIL-L-85762A, "Lighting, Aircraft, Interior Night Vision, Imaging System (NVIS)." This document has been superseded by U.S. Department of Defense Interface Standard, MIL-STD-3009, *Lighting, Aircraft, Night Vision Imaging System (NVIS) Compatible*. Washington, D.C., U.S.: Department of Defense, Feb. 2, 2001.
32. Pope, S. *Versatility of Flexible Displays Intrigues Flight Deck Designers*. <www.ainonline.com/issues/02_02/02_02_versatilitypg60.html>. 2002. July 13, 2003.

About the Authors

Clarence E. Rash is a research physicist at the U.S. Army Aeromedical Research Laboratory (USAARL), Fort Rucker, Alabama, U.S. He has 25 years of experience in Army aviation research and development and is the editor of *Helmet-Mounted Display: Design Issues for Rotary Wing Aircraft*, SPIE Press, 2000. Sharon D. Manning is a safety and occupational health specialist at the Aviation Branch Safety Office (ABSO), Fort Rucker. She has 12 years of experience in U.S. Army aviation.

Want more information about Flight Safety Foundation?

Contact Ann Hill, director, membership and development,
by e-mail: hill@flightsafety.org or by telephone: +1 (703) 739-6700, ext. 105.

Visit our Internet site at <www.flightsafety.org>.

We Encourage Reprints

Articles in this publication, in the interest of aviation safety, may be reprinted, in whole or in part, but may not be offered for sale, used commercially or distributed electronically on the Internet or on any other electronic media without the express written permission of Flight Safety Foundation's director of publications. All uses must credit Flight Safety Foundation, *Human Factors & Aviation Medicine*, the specific article(s) and the author(s). Please send two copies of the reprinted material to the director of publications. These restrictions apply to all Flight Safety Foundation publications. Reprints must be ordered from the Foundation.

What's Your Input?

In keeping with the Foundation's independent and nonpartisan mission to disseminate objective safety information, FSF publications solicit credible contributions that foster thought-provoking discussion of aviation safety issues. If you have an article proposal, a completed manuscript or a technical paper that may be appropriate for *Human Factors & Aviation Medicine*, please contact the director of publications. Reasonable care will be taken in handling a manuscript, but Flight Safety Foundation assumes no responsibility for material submitted. The publications staff reserves the right to edit all published submissions. The Foundation buys all rights to manuscripts and payment is made to authors upon publication. Contact the Publications Department for more information.

Human Factors & Aviation Medicine

Copyright © 2003 by Flight Safety Foundation Inc. All rights reserved. ISSN 1057-5545

Suggestions and opinions expressed in FSF publications belong to the author(s) and are not necessarily endorsed by Flight Safety Foundation. This information is not intended to supersede operators'/manufacturers' policies, practices or requirements, or to supersede government regulations.

Staff: Roger Rozelle, director of publications; Mark Lacagnina, senior editor; Wayne Rosenkrans, senior editor; Linda Werfelman, senior editor; Rick Darby, associate editor; Karen K. Ehrlich, web and print production coordinator; Ann L. Mullikin, production designer; Susan D. Reed, production specialist; and Patricia Setze, librarian, Jerry Lederer Aviation Safety Library

Subscriptions: One year subscription for six issues includes postage and handling: US\$240. Include old and new addresses when requesting address change. • Attention: Ahlam Wahdan, membership services coordinator, Flight Safety Foundation, Suite 300, 601 Madison Street, Alexandria, VA 22314 U.S. • Telephone: +1 (703) 739-6700 • Fax: +1 (703) 739-6708